

SMARTplus+
ÇEK-SÜR KAPI ve PENCERE SİSTEMİ
PULL&SLIDE DOOR and WINDOW SYSTEM

A	ISI HESAPLARI ve KANAT SEÇİMİ THERMAL CALCULATIONS and STATICAL DIAGRAM	A-01 / A-08
B	ALUMİNYUM PROFİLLER ALUMINIUM PROFILES	B-01 / B-04
C	CAM MONTAJ TALİMATI GLAZING ASSEMBLY	C-01 / C-03
D	CONTALAR GASKETS	D-01 / D-02
E	AKSESUARLAR ACCESSORIES	E-01 / E-02
F	PVC PROFİLLER PVC PROFILES	F-01
G	TAM ÖLÇEKLİ PROFİLLER FULL SCALE PROFILES	G-01 / G-08
H	PRENSİP SİSTEM DETAYLARI PRINCIPAL SECTIONS	H-01 / H-08

SMARTplus+
ÇEK-SÜR KAPI ve PENCERE SİSTEMİ
PULL&SLIDE DOOR and WINDOW SYSTEM

ISI HESAPLARI ve PERFORMANS
THERMAL CALCULATIONS
and PERFORMANCE

SMARTplus+

ÇEK-SÜR KAPI ve PENCERE SİSTEMİ

PULL&SLIDE DOOR and WINDOW SYSTEM

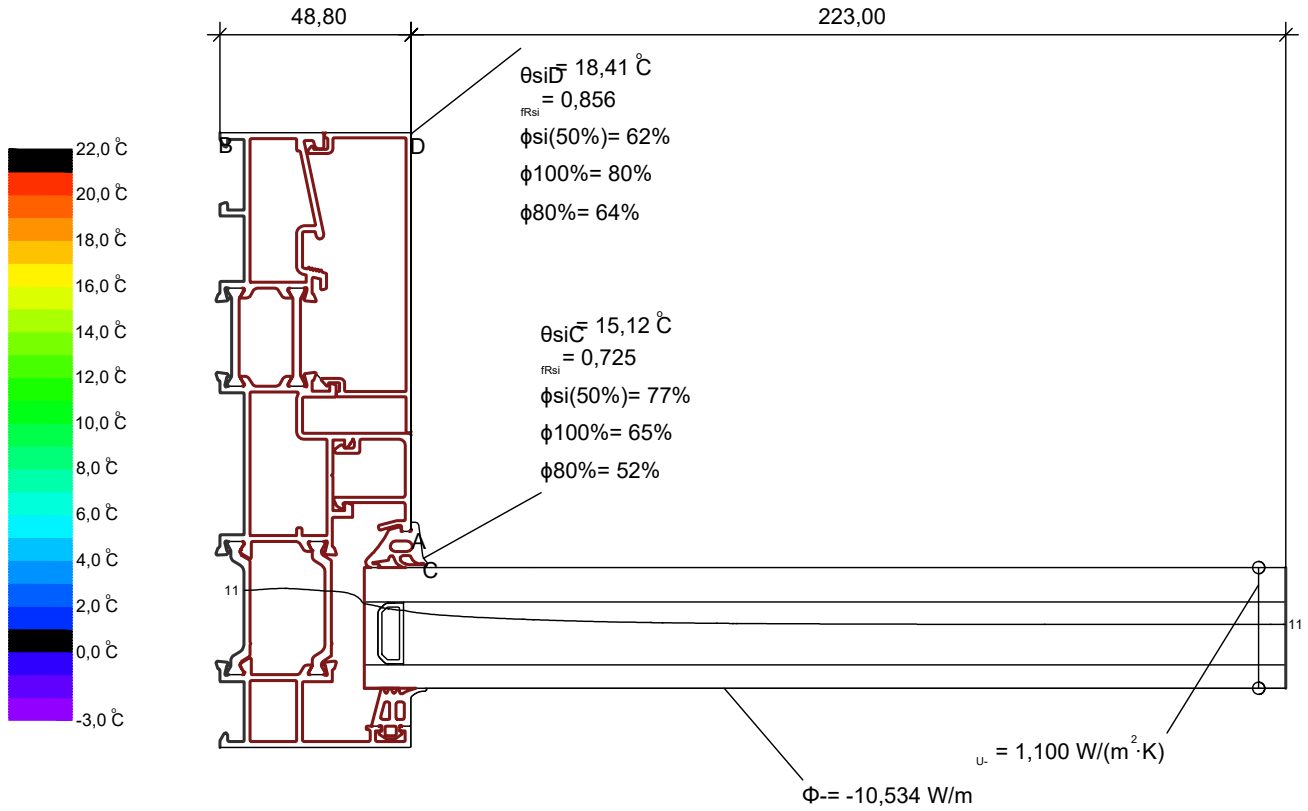

$$UTJ_{A,B} = \frac{\Phi}{\Delta T} = \frac{10,534}{25,000} = 0,42136$$

$$UTJ_{A,B} = \frac{1}{\frac{1}{U_g} + \frac{b_g}{b_f}} = \frac{1}{\frac{1}{1,100} + \frac{0,223}{0,049}} = 0,049$$

$$UTJ_{A,B} = \frac{10,534}{25,000} = 0,42136 = \frac{1}{\frac{1}{1,100} + \frac{0,223}{0,049}} = 3,61 \text{ W/(m}^2 \cdot \text{K)}$$

Material	λ [W/(m·K)]	ϵ	Boundary Condition	q [W/m ²]	θ [C°]	R [(m·K)/W]	ϵ
Aluminium (Si Alloys)	160,000	0,900	Epsilon 0.9				0,900
Butyl (Isobuten), heissgeschmolzen	0,240		Exterior, frame	-3,000			0,040
EPDM (ethylene propylene diene monomer)	0,250	0,900	Interior, frame, normal	22,000			0,130
Edelstahl, Fa. SGG	15,000		Interior, frame, reduced	22,000			0,200
Gasfilling(1)	0,022		Symmetry/Model section	0,000			
Polyamid 6.6 with 25% glass fibre	0,300	0,900					
Polysulfid	0,400	0,900					
SAN 35% glass fiber	0,160						
Silicagel (Trockenmittel)	0,130						
Soda lime glass	1,000	0,900					
Unventilated air cavity	anisotropic						

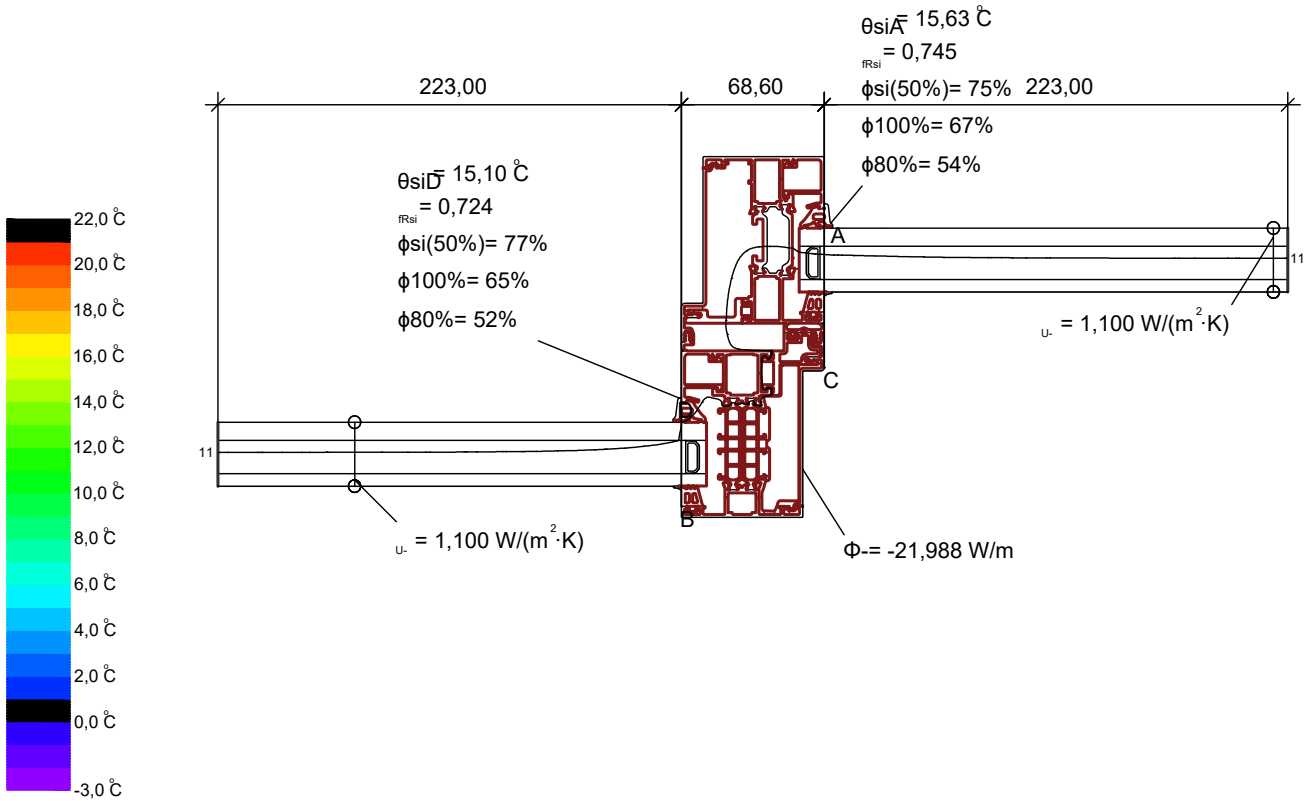

$$U_{TJ} = \frac{\Phi}{\Delta T} = \frac{21,988}{25,000 - 1,100 \cdot 0,223 - 1,100 \cdot 0,223} = \frac{21,988}{0,069} = 5,67 \text{ W/(m}^2\text{K)}$$

Material	λ [W/(m·K)]	ϵ	Boundary Condition q [W/m ²]	θ [C°]	R [(m·K) ² /W]	ϵ
Aluminium (Si Alloys)	160,000	0,900	Epsilon 0.9			0,900
Butyl (Isobuten), heissgeschmolzen	0,240		Exterior, frame	-3,000	0,040	
EPDM (ethylene propylene diene monomer)	0,250	0,900	Interior, frame, normal	22,000	0,130	
Edelstahl, Fa. SGG	15,000		Interior, frame, reduced	22,000	0,200	
Gasfilling(1)	0,022		Symmetry/Model section	0,000		
Polyamid 6.6 with 25% glass fibre	0,300	0,900				
Polysulfid	0,400	0,900				
SAN 35% glass fiber	0,160					
Silicagel (Trockenmittel)	0,130					
Soda lime glass	1,000	0,900				
Unventilated air cavity	anisotropic					

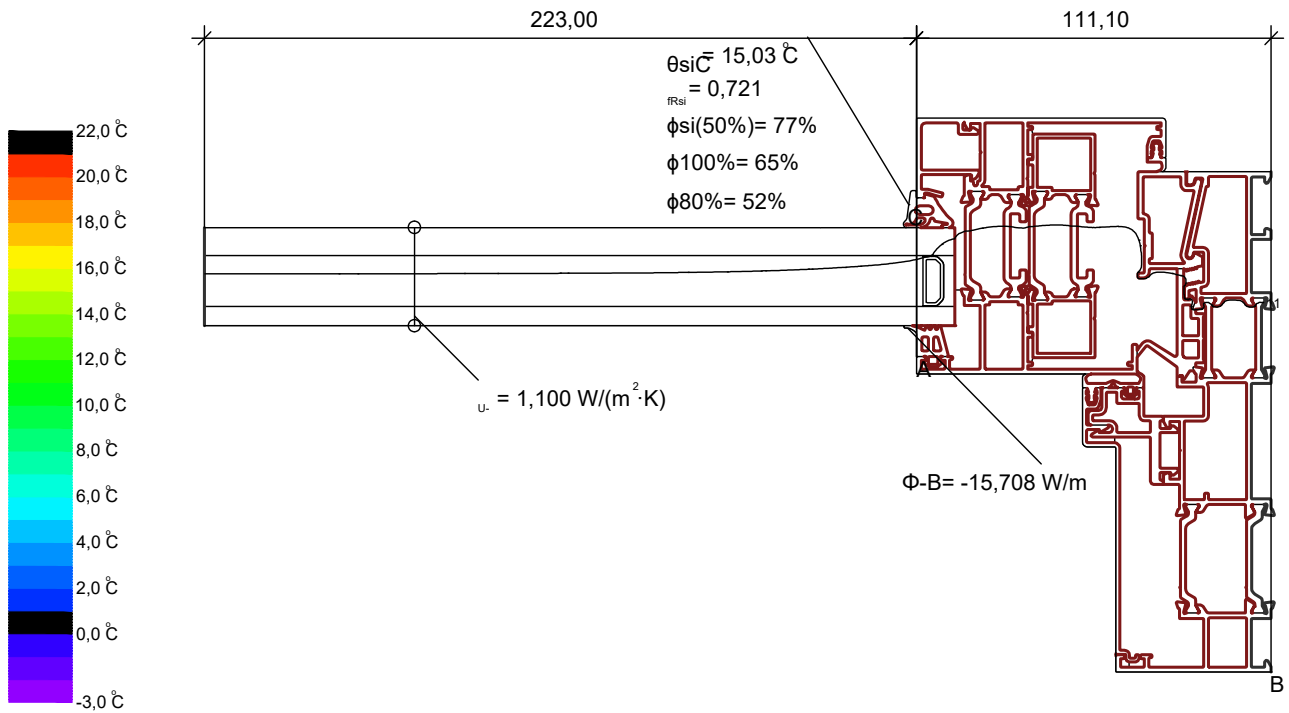

$$\begin{aligned}
 \text{UTJ A,B} &= \frac{\Phi}{\Delta T} - U_g \cdot b_g = \frac{15,708}{25,000} - 1,100 \cdot 0,223 \\
 &= \frac{0,628}{0,111} = 3,45 \text{ W/(m} \cdot \text{K)}
 \end{aligned}$$

Material	λ [W/(m·K)]	ϵ	Boundary Condition	q [W/m ²]	θ [C°]	R [(m·K) ² /W]	ϵ
Aluminium (Si Alloys)	160,000	0,900	Epsilon 0.9				0,900
Butyl (Isobuten), heissgeschmolzen	0,240		Exterior, frame	-3,000		0,040	
EPDM (ethylene propylene diene monomer)	0,250	0,900	Interior, frame, normal	22,000		0,130	
Edelstahl, Fa. SGG	15,000		Interior, frame, reduced	22,000		0,200	
Gasfilling(1)	0,022		Symmetry/Model section	0,000			
Polyamid 6.6 with 25% glass fibre	0,300	0,900					
Polysulfid	0,400	0,900					
SAN 35% glass fiber	0,160						
Silicagel (Trockenmittel)	0,130						
Soda lime glass	1,000	0,900					
Unventilated air cavity	anisotropic						

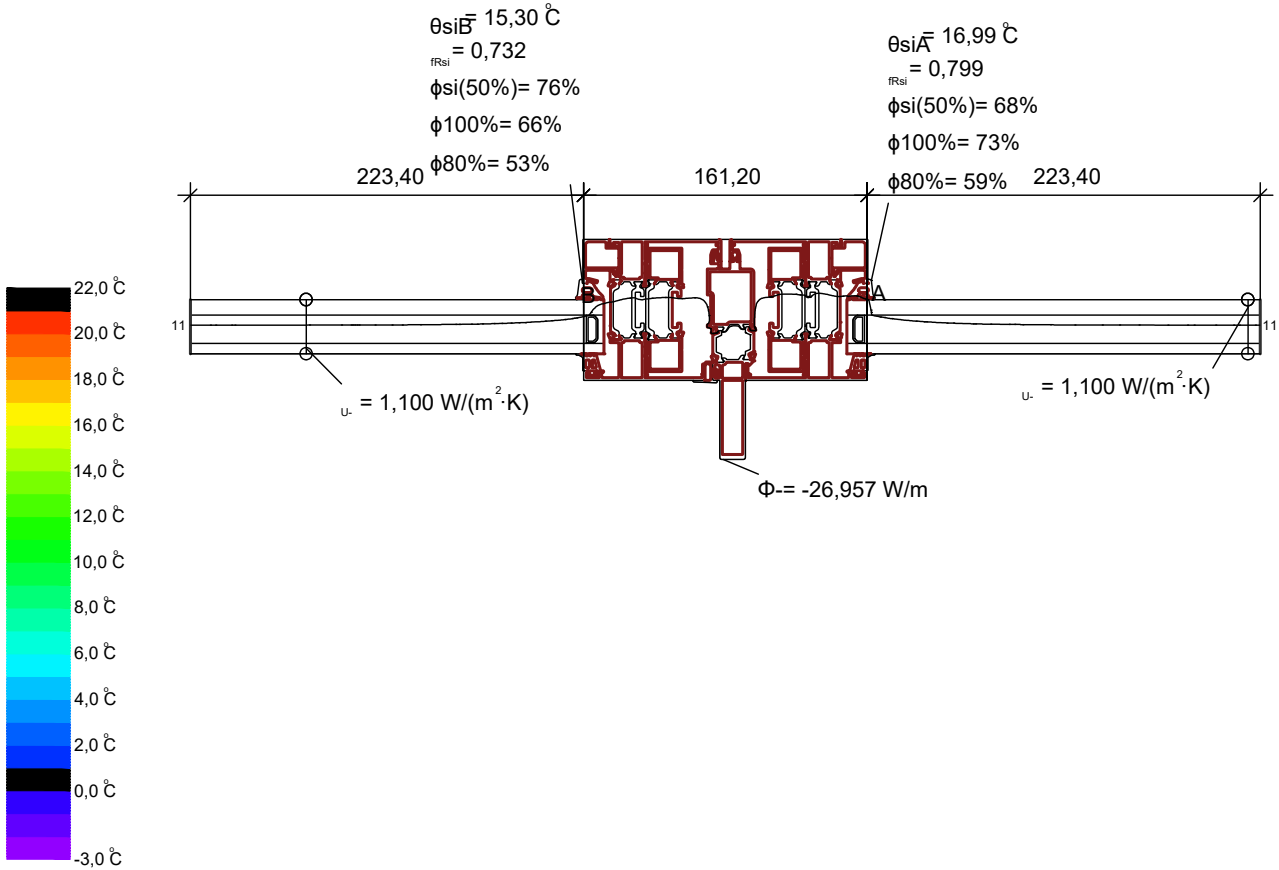

$$\begin{aligned}
 \frac{\Phi}{\Delta T} &= \frac{\Phi}{U_{TJ} \cdot b_f} = \frac{26,957}{0,161} = 167,435 \text{ W/(m}^2\cdot\text{K)} \\
 &= \frac{26,957}{\frac{1}{1,100} + \frac{0,223}{1,100}} = 167,435 \text{ W/(m}^2\cdot\text{K)}
 \end{aligned}$$

Material	λ [W/(m·K)]	ϵ	Boundary Condition q [W/m ²]	θ [°C]	R [(m·K) ² /W]	ϵ
Aluminium (Si Alloys)	160,000	0,900	Epsilon 0.9			0,900
Butyl (Isobuten), heissgeschmolzen	0,240		Exterior, frame	-3,000	0,040	
EPDM (ethylene propylene diene monomer)	0,250	0,900	Interior, frame, normal	22,000	0,130	
Edelstahl, Fa. SGG	15,000		Interior, frame, reduced	22,000	0,200	
Gasfilling(1)	0,022		Symmetry/Model section	0,000		
Polyamid 6.6 with 25% glass fibre	0,300	0,900				
Polysulfid	0,400	0,900				
SAN 35% glass fiber	0,160					
Silicagel (Trockenmittel)	0,130					
Soda lime glass	1,000	0,900				
Unventilated air cavity	anisotropic					

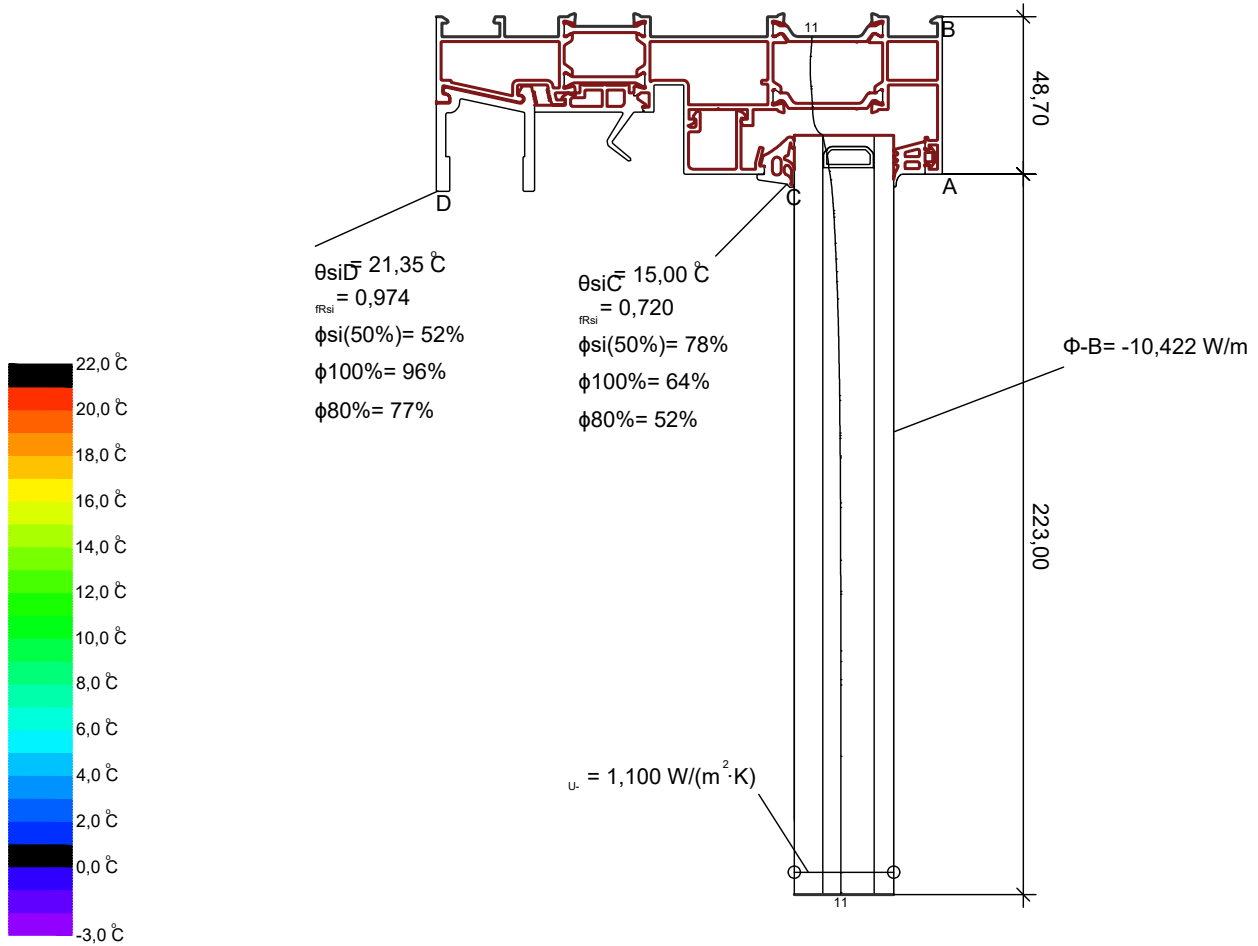

$$\begin{aligned}
 \frac{\Phi}{\Delta T} &= \frac{\Phi}{\Delta T} \cdot \frac{b_f}{b_f} = \frac{10,422}{25,000} - 1,100 \cdot 0,223 \\
 &= \frac{0,41688}{0,049} = 3,52 \text{ W/(m}^2\cdot\text{K)}
 \end{aligned}$$

Material	λ [W/(m·K)]	ϵ	Boundary Condition	q [W/m ²]	θ [°C]	R [(m·K) ² /W]	ϵ
Aluminium (Si Alloys)	160,000	0,900	Epsilon 0.9				0,900
Butyl (Isobuten), heissgeschmolzen	0,240		Exterior, frame	-3,000			0,040
EPDM (ethylene propylene diene monomer)	0,250	0,900	Interior, frame, normal	22,000			0,130
Edelstahl, Fa. SGG	15,000		Interior, frame, reduced	22,000			0,200
Gasfilling(1)	0,022		Symmetry/Model section	0,000			
Polyamid 6.6 with 25% glass fibre	0,300	0,900					
Polysulfid	0,400	0,900					
SAN 35% glass fiber	0,160						
Silicagel (Trockenmittel)	0,130						
Soda lime glass	1,000	0,900					
Unventilated air cavity	anisotropic						

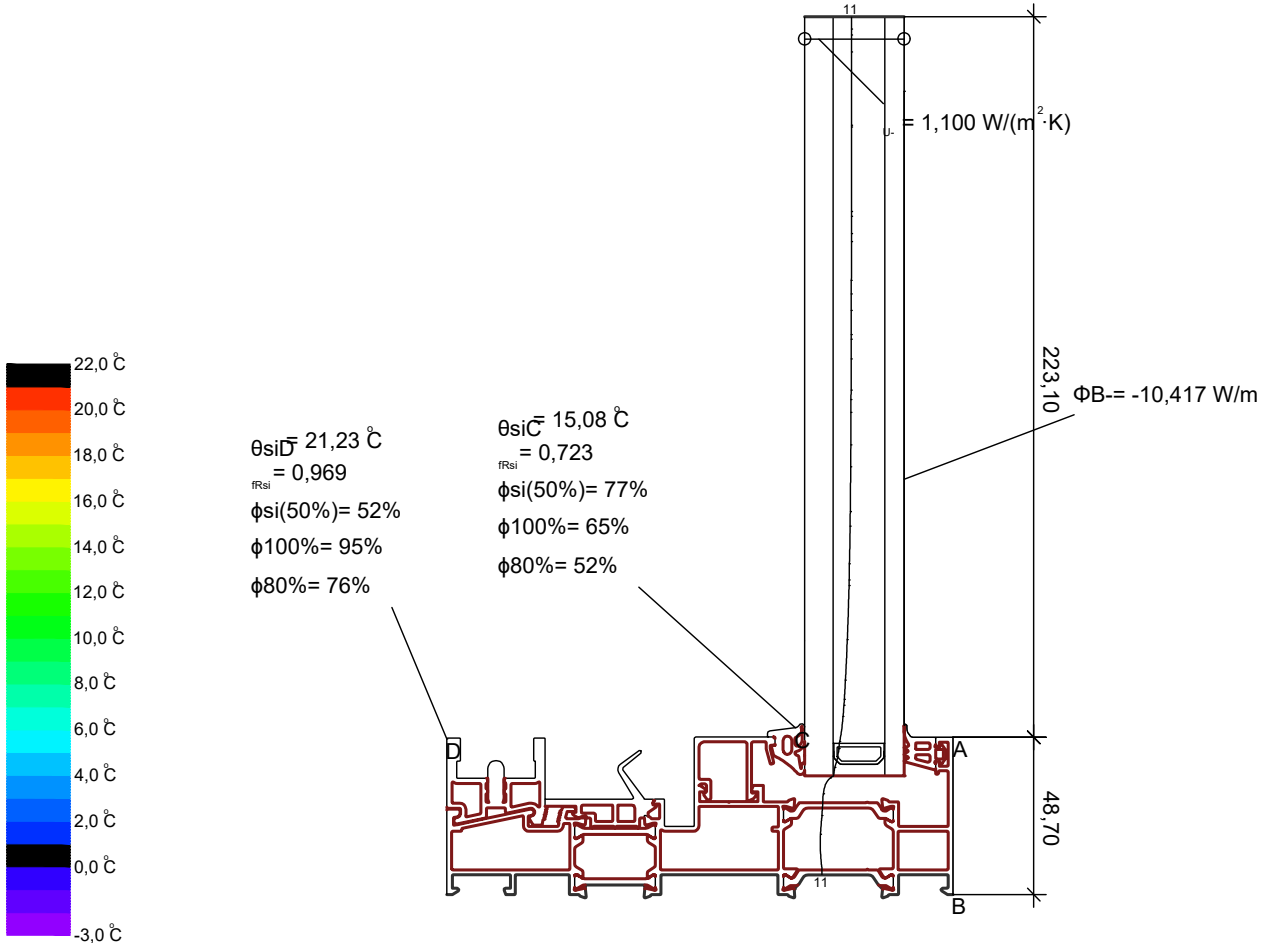

$$\begin{aligned}
 \frac{\Phi}{\Delta T} &= \frac{\Phi}{\Delta T} \cdot \frac{b_f}{b_f} = \frac{10,417}{25,000} \cdot \frac{0,300}{0,049} = 3,52\text{ W/(m}^2\cdot\text{K)} \\
 \text{UTJ A,B} &= \frac{\Phi}{\Delta T} \cdot U_g \cdot b_g = \frac{10,417}{25,000} \cdot 1,100 \cdot 0,223 = 0,049
 \end{aligned}$$

Material	λ [W/(m·K)]	ϵ	Boundary Condition q [W/m ²]	θ [C°]	R [(m·K) ² /W]	ϵ
Aluminium (Si Alloys)	160,000	0,900	Epsilon 0.9			0,900
Butyl (Isobuten), heissgeschmolzen	0,240		Exterior, frame	-3,000	0,040	
EPDM (ethylene propylene diene monomer)	0,250	0,900	Interior, frame, normal	22,000	0,130	
Edelstahl, Fa. SGG	15,000		Interior, frame, reduced	22,000	0,200	
Gasfilling(1)	0,022		Symmetry/Model section	0,000		
Polyamid 6.6 with 25% glass fibre	0,300	0,900				
Polysulfid	0,400	0,900				
SAN 35% glass fiber	0,160					
Silicagel (Trockenmittel)	0,130					
Soda lime glass	1,000	0,900				
Unventilated air cavity	anisotropic					

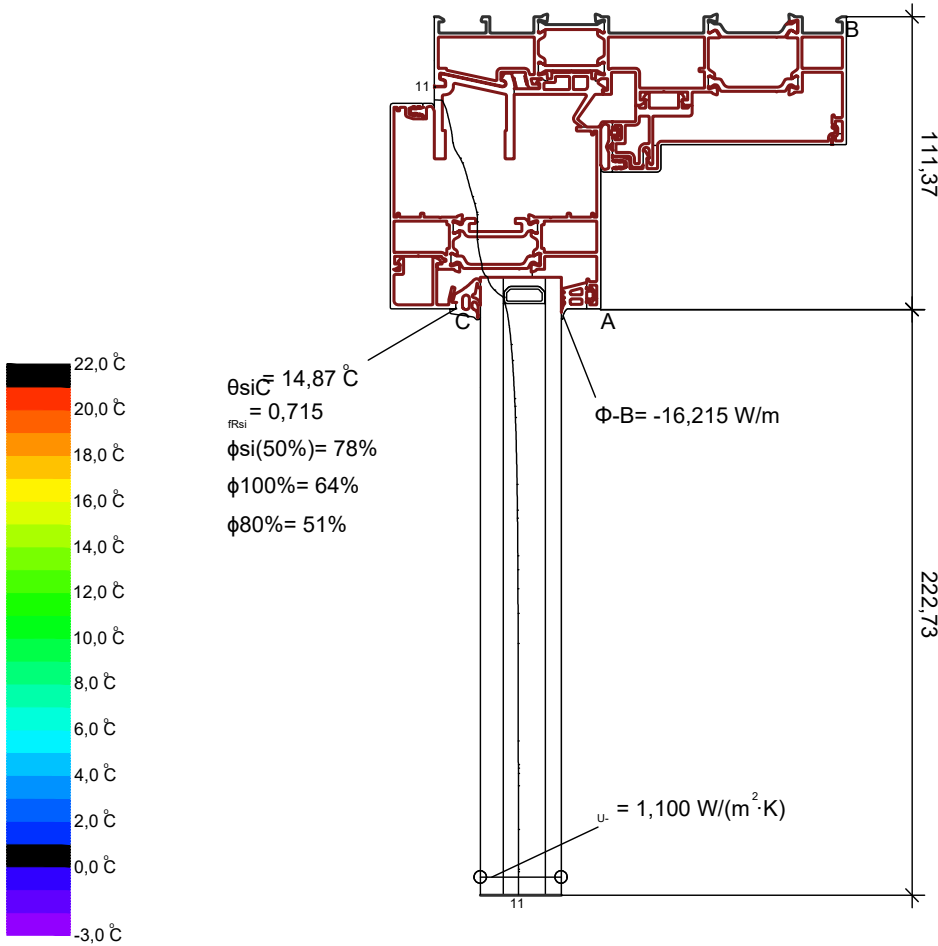

$$U_{TJ A,B} = \frac{\Phi}{\Delta T} = \frac{\Phi}{\Delta T} \cdot \frac{b_g}{b_f} = \frac{16,215}{25,000} - 1,100 \cdot 0,223 = \frac{0,111}{0,111} = 3,62 \text{ W/(m}^2 \cdot \text{K)}$$

Material	λ [W/(m·K)]	ϵ	Boundary Condition q [W/m ²]	θ [C°]	R [(m·K) ² /W]	ϵ
Aluminium (Si Alloys)	160,000	0,900	Epsilon 0.9			0,900
Butyl (Isobuten), heissgeschmolzen	0,240		Exterior, frame	-3,000	0,040	
EPDM (ethylene propylene diene monomer)	0,250	0,900	Interior, frame, normal	22,000	0,130	
Edelstahl, Fa. SGG	15,000		Interior, frame, reduced	22,000	0,200	
Gasfilling(1)	0,022		Symmetry/Model section	0,000		
Polyamid 6.6 with 25% glass fibre	0,300	0,900				
Polysulfid	0,400	0,900				
SAN 35% glass fiber	0,160					
Silicagel (Trockenmittel)	0,130					
Soda lime glass	1,000	0,900				
Unventilated air cavity	anisotropic					

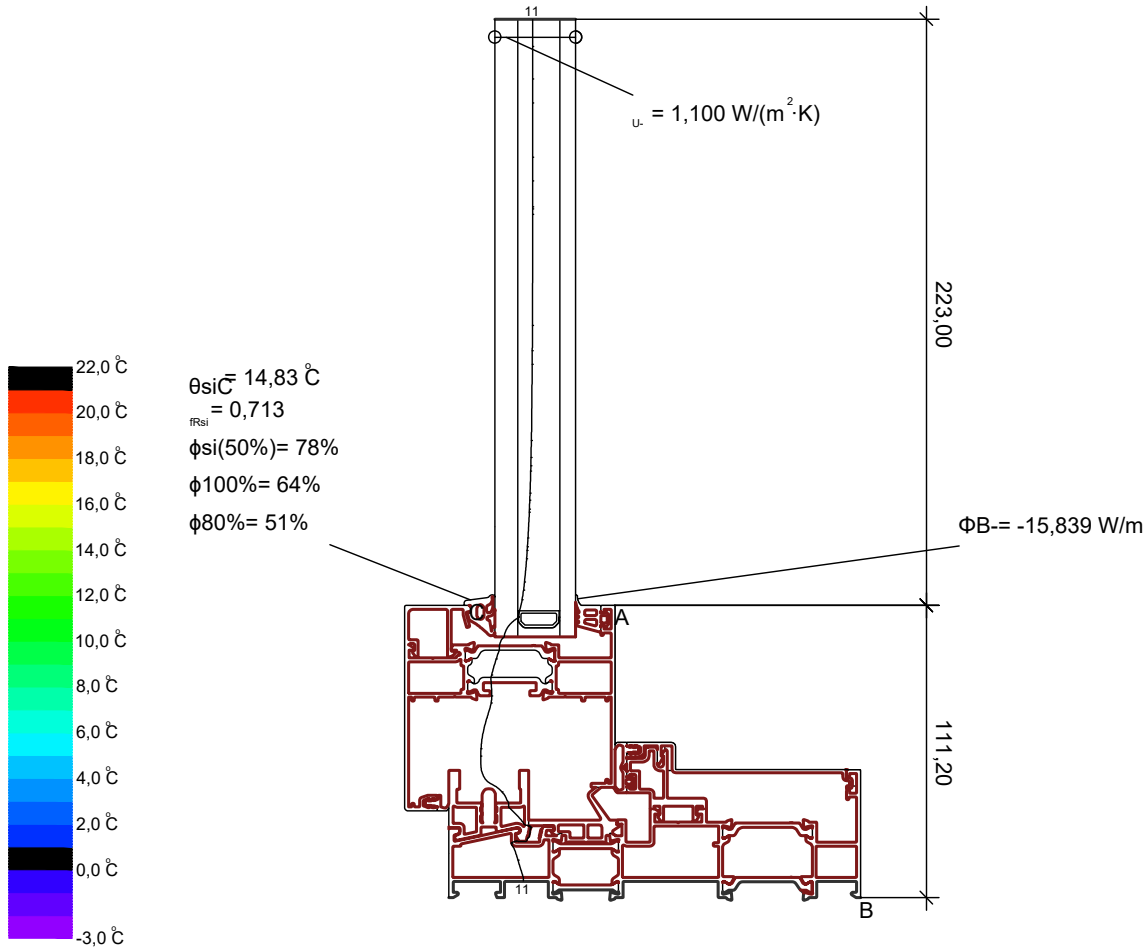

$$\begin{aligned}
 \text{UTJ A,B} &= \frac{\Phi}{\Delta T} = \frac{-U_g \cdot b_g}{b_f} = \frac{15,839}{25,000} - 1,100 \cdot 0,223 \\
 &= \frac{15,839}{25,000} - 0,2453 = 0,2453 - 0,2453 = 0,000 \text{ W}/(\text{m}^2 \cdot \text{K})
 \end{aligned}$$

Material	λ [W/(m·K)]	ϵ	Boundary Condition q [W/m ²]	θ [C°]	R [(m·K) ² /W]	ϵ
Aluminium (Si Alloys)	160,000	0,900	Epsilon 0.9			0,900
Butyl (Isobuten), heissgeschmolzen	0,240		Exterior, frame	-3,000	0,040	
EPDM (ethylene propylene diene monomer)	0,250	0,900	Interior, frame, normal	22,000	0,130	
Edelstahl, Fa. SGG	15,000		Interior, frame, reduced	22,000	0,200	
Gasfilling(1)	0,022		Symmetry/Model section	0,000		
Polyamid 6.6 with 25% glass fibre	0,300	0,900				
Polysulfid	0,400	0,900				
SAN 35% glass fiber	0,160					
Silicagel (Trockenmittel)	0,130					
Soda lime glass	1,000	0,900				
Unventilated air cavity	anisotropic					

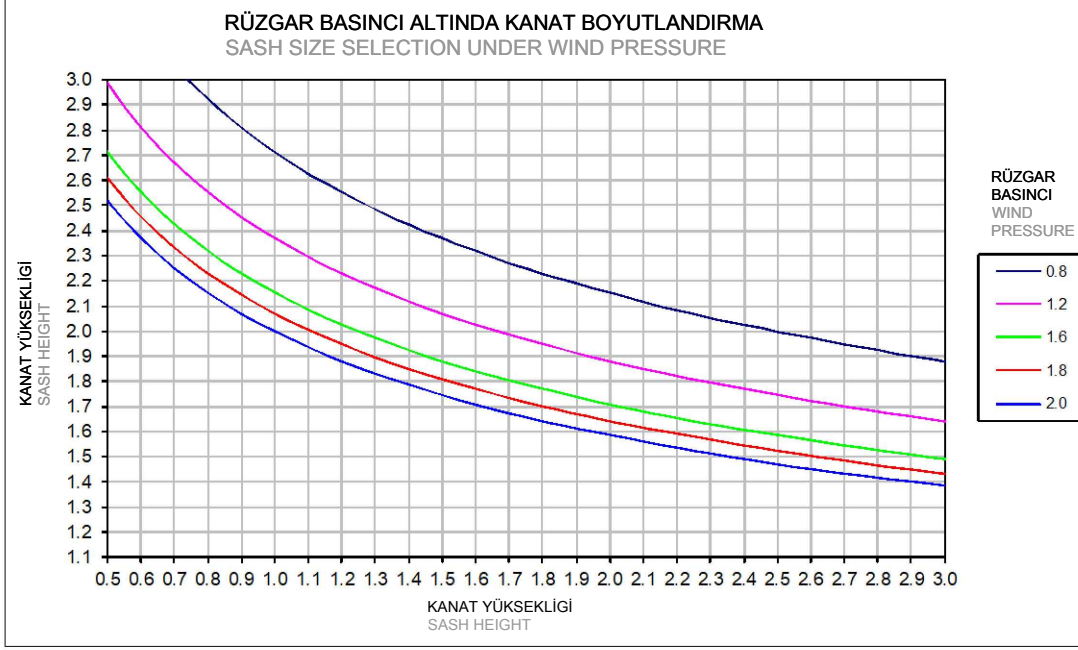

KANAT STATİK DİAGRAM
STATICAL DIAGRAM for SASH

KANAT AĞIRLIĞI : 400kg
SASH WEIGHT : 400kg

SEHİM LİMİTİ L/200 yada 15mm dir.

FARKLI RENKLİ EGRİSEL ÇİZGİLER, FARKLI RÜZGAR BASINCLARI ALTINDA, UYGULANABİLİR MAKSİMUM KANAT BOYUTLARINI GÖSTERİR.

ÜSTTEKİ TABLOYA GÖRE SEÇİLEN KANAT BOYUTU, CAM TEDARİKÇİSİNE BİLDİRİLEREK, İZİN VERİLEN BOYUT ve SEHİMİN, SEÇİLEN

CAMA UYGUN OLUP OLMADIĞI TEYİD EDİLMELİ ve ONAY ALINMALIDIR.

DİKKAT:

Bu statik hesap şeması ön yapısal hesaplamalar ve profil seçimi için tasarlanmıştır.

Bu şema nihai yapısal hesaplama için bir alternatif değildir, Statik Rapor olarak kullanılamaz

Statik Hesaplar Mutlaka Uygulamacı Tarafından Yapılmalıdır.

DEFLECTION LIMIT L / 200 or 15mm.

THE LINE SHOW MAXIMUM SIZES FOR THE INDICATE PRESSURE.

VERIFY THAT THE DEFLECTION OF THE SECTION IS COMPATIBLE WITH THE EMPLOYED GLASS.

DIN EN 12210 for the standard building area

Deflection limit L/200 or max. 15mm in accordance with TRLV

Differing deflection limits set by the double glazing manufacturer must be observed.

These statics diagram are intended for preliminary structural calculations and profile selection.

This is not a substitute for a final structural calculation.

Sash sizes below the line are structurally adequate.

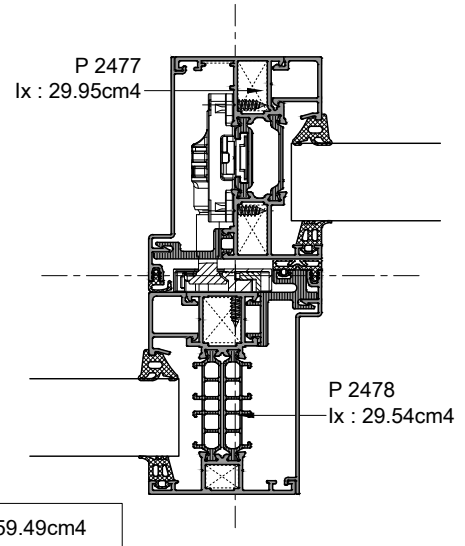
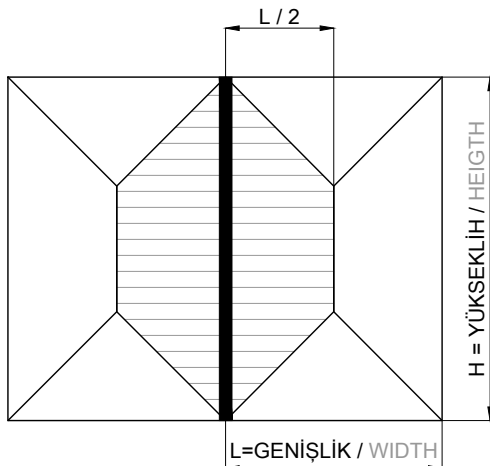

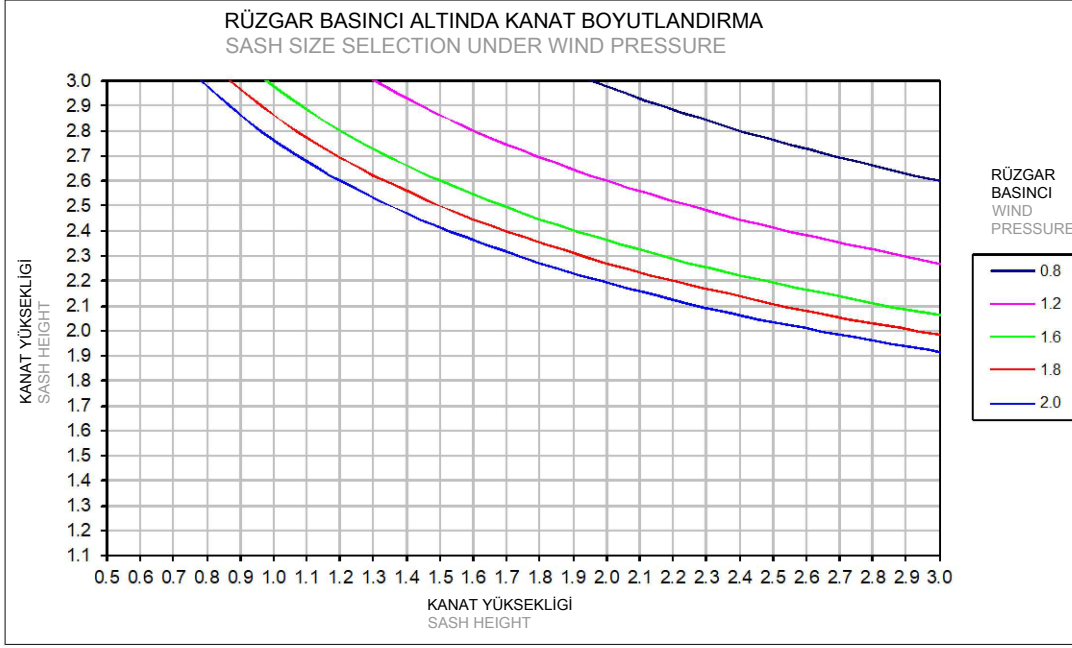

KANAT STATİK DİAGRAM
STATICAL DIAGRAM for SASH

KANAT AĞIRLIĞI : 400kg
SASH WEIGHT : 400kg

SEHİM LİMİTİ L/200 yada 15mm dir.

FARKLI RENKLİ EGRİSEL ÇİZGİLER, FARKLI RÜZGAR BASINCLARI ALTINDA, UYGULANABİLİR MAKSİMUM KANAT BOYUTLARINI GÖSTERİR.

ÜSTTEKİ TABLOYA GÖRE SEÇİLEN KANAT BOYUTU, CAM TEDARİKÇİSİNE BİLDİRİLEREK, İZİN VERİLEN BOYUT ve SEHİMİN, SEÇİLEN

CAMA UYGUN OLUP OLMADIĞI TEYİD EDİLMELİ ve ONAY ALINMALIDIR.

DİKKAT:

Bu statik hesap şeması ön yapısal hesaplamalar ve profil seçimi için tasarlanmıştır.

Bu şema nihai yapısal hesaplama için bir alternatif değildir, Statik Rapor olarak kullanılamaz.

Statik Hesaplar Mutlaka Uygulamacı Tarafından Yapılmalıdır.

DEFLECTION LIMIT L / 200 or 15mm.

THE LINE SHOW MAXIMUM SIZES FOR THE INDICATE PRESSURE.

VERIFY THAT THE DEFLECTION OF THE SECTION IS COMPATIBLE WITH THE EMPLOYED GLASS.

DIN EN 12210 for the standard building area

Deflection limit L/200 or max. 15mm in accordance with TRLV

Differing deflection limits set by the double glazing manufacturer must be observed.

These statics diagram are intended for preliminary structural calculations and profile selection.

This is not a substitute for a final structural calculation.



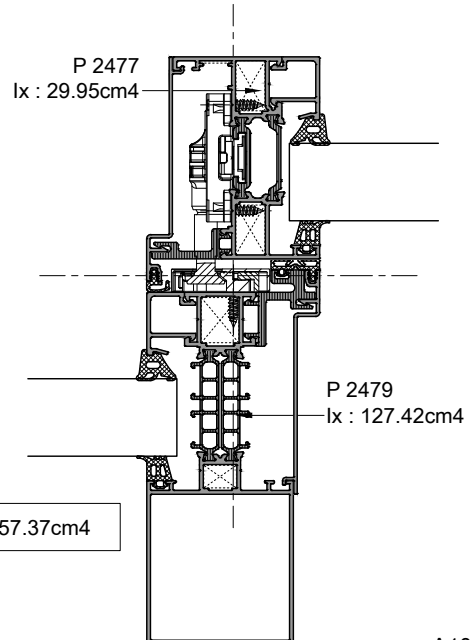
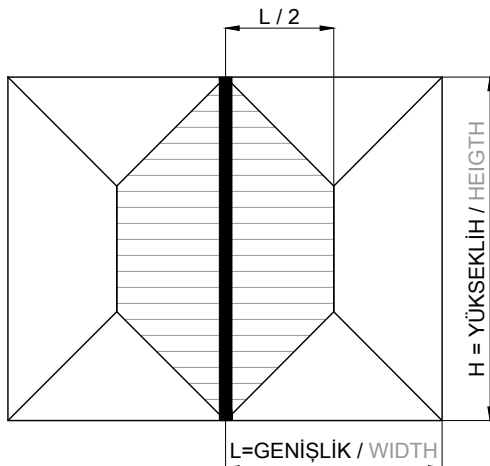

Sash sizes below the line are structurally adequate.



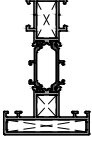
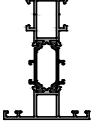
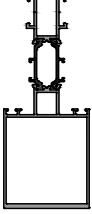
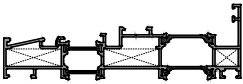
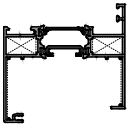

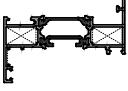
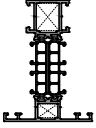
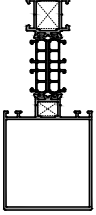









SMARTplus+
ÇEK-SÜR KAPI ve PENCERE SİSTEMİ
PULL&SLIDE DOOR and WINDOW SYSTEM

ALUMİNYUM PROFİLLER
ALUMINIUM PROFILES

PROFİL ŞEKLİ PROFILE SECTION	PROFİL ADI PROFILE NO	KALIP KODU DIE NO	PROFİL TANIMI PROFILE DESCRIPTION	AĞIRLIK WEIGHT
	P 2193	18092 + 18280	ORTA KAYIT PROFİLİ mullion profile	1,770kg/mt
	P 2405	18092 + 18907	ORTA KAYIT PROFİLİ mullion profile	1,425kg/mt
	P 2407	18092 + 18906	ORTA KAYIT PROFİLİ mullion profile	2,405kg/mt
	P 2194	19658 + 19659 + 19660	KASA PROFİLİ frame profile	2,470kg/mt
	P 2476	19663 + 19664	KANAT PROFİLİ sash profile	1,620kg/mt

PROFİL ŞEKLİ PROFILE SECTION	PROFİL ADI PROFILE NO	KALIP KODU DIE NO	PROFİL TANIMI PROFILE DESCRIPTION	AĞIRLIK WEIGHT
	P 2477	19661 + 19662	KANAT PROFİLİ sash profile	1,365kg/mt
	P 2478	19665 + 19666	ORTA KAYIT PROFİLİ mullion profile	1,415kg/mt
	P 2479	19665 + 19667	ORTA KAYIT PROFİLİ mullion profile	2,200kg/mt
	P 1020	12769	TİJ PROFİLİ rod profile	0,105kg/mt
	P 2480	19669 + 19670	ÇİFT KANAT ADAPTOR PROFİLİ double sash adapter profile	1,510kg/mt
	P 2481	19671 + 19671	KANAT ADAPTOR PROFİLİ sash adapter profile	0,880kg/mt
	P 2482	19676	KAPAK PROFİLİ closing profile	0,420kg/mt

PROFİL ŞEKLİ PROFILE SECTION	PROFİL ADI PROFILE NO	KALIP KODU DIE NO	PROFİL TANIMI PROFILE DESCRIPTION	AĞIRLIK WEIGHT
	P 2483	19675	KAPAK PROFİLİ closing profile	0,460kg/mt
	P 2484	19672	ALT RAY PROFİLİ bottom rail profile	0,690kg/mt
	P 2485	19673	ÜST RAY PROFİLİ top rail profile	0,765kg/mt
	P 2486	19674	YAN RAY PROFİLİ side rail profile	0,485kg/mt
	P 2487	19677	BİTİŞ PROFİLİ finishing profile	0,120kg/mt
	P 2488	19678	RAY PROFİLİ rail profile	0,170kg/mt
	P 2180		12,5mm CAM ÇITASI 12,5mm glazing bead profile	0,240kg/mt
	P 2181	18279	18,5mm CAM ÇITASI 18,5mm glazing bead profile	0,285kg/mt
	P 2182	18096	25mm CAM ÇITASI 25mm glazing bead profile	0,295kg/mt
	P 2183		30,5mm CAM ÇITASI 30,5mm glazing bead profile	0,320kg/mt

PROFİL ŞEKLİ PROFILE SECTION	PROFİL ADI PROFILE NO	KALIP KODU DIE NO	PROFİL TANIMI PROFILE DESCRIPTION	AĞIRLIK WEIGHT
	P 2184		36,5mm CAM ÇITASI 36,5mm glazing bead profile	0,340kg/mt
	P 1163	4292	KÖŞE TAKOZ PROFİLİ corner cleat profile	3,750kg/mt

SMARTplus+
ÇEK-SÜR KAPI ve PENCERE SİSTEMİ
PULL&SLIDE DOOR and WINDOW SYSTEM

CAM MONTAJ TALİMATI
GLAZING ASSEMBLY

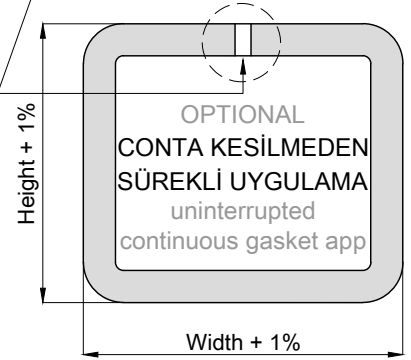
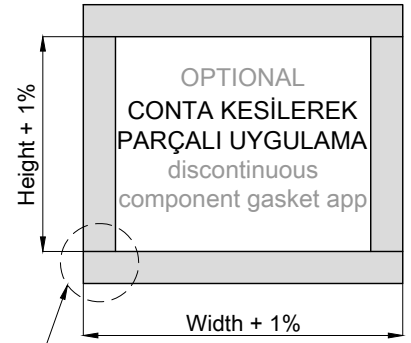
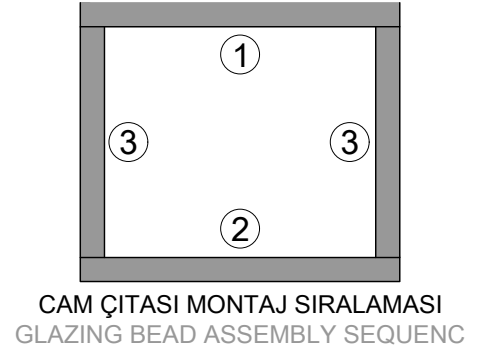
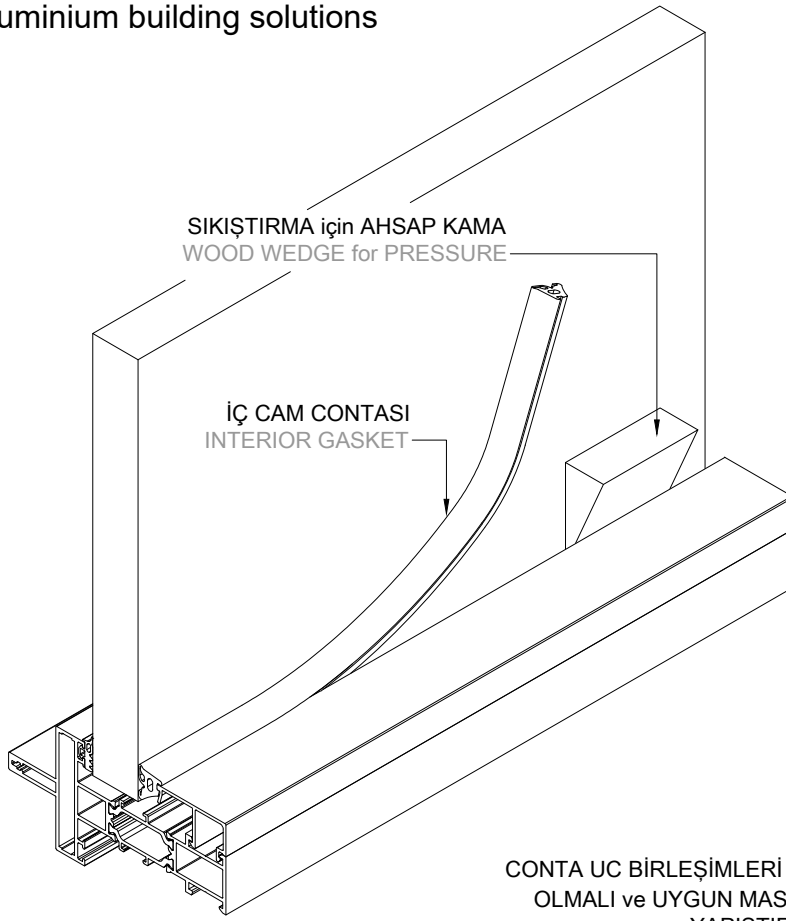

CONTA UC BİRLEŞİMLERİ ÜSTTE
OLMALI ve UYGUN MASTİK İLE
YAPIŞTIRILMALI
GASKET JOINT ON THE TOP,
BOND WITH EPDM GLUE.

① CAM TAKOZU

Cam takozları yerleşimi altta bulunan sematik çizimde gösterilmiştir. takozların kenara mesafeleri kanat ölçüsünün 5/1 i yada 10/1 i kadar olmalıdır.

GLASS CLEATS

The assembly of glass reinforcement pieces has been showed at the top schematically. The gap distance to the corner should be, the 5/1 or 10/1 of the sash size.

② MESAFE AYARLAMA TAKOZU

Mesafe ayar takozları camın alüminyum çerçeve içinde doğru pozisyonda stabil olarak durmasını sağlar.





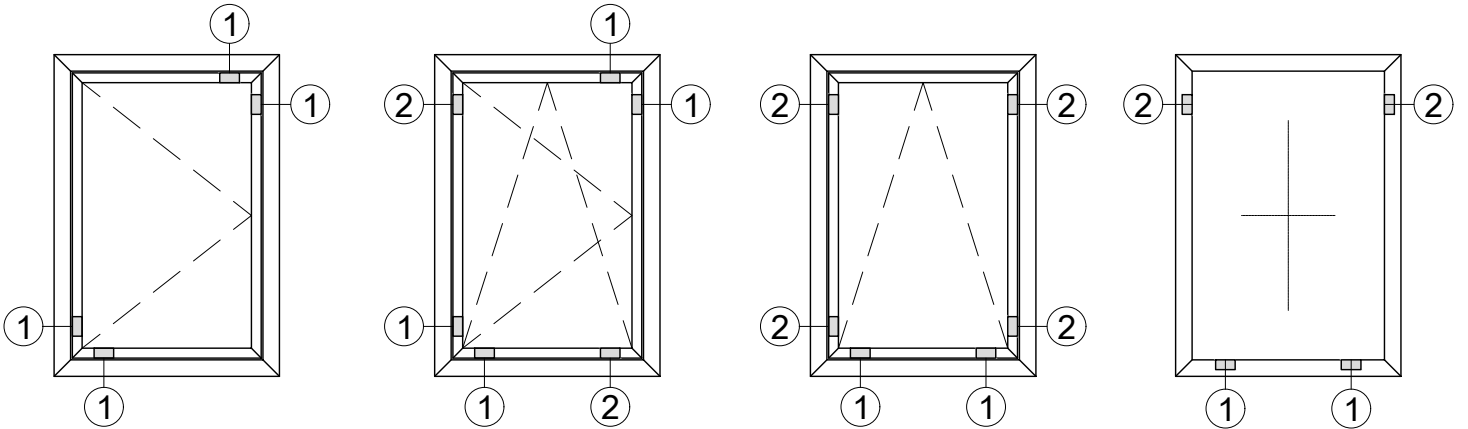





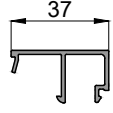



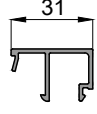



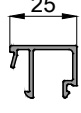

DISTANCE ADJUSTMENT PIECE

Distance adjustment pieces stabilize the glass in the frame at the true position. Put the distance adjustment piece between glass and profile without using force.









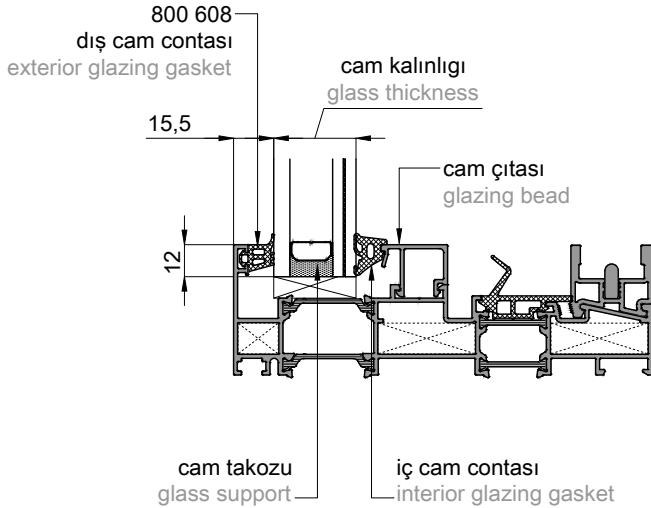



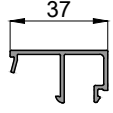



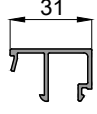



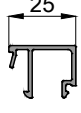

AKSESUAR ve DONANIM MONTAJINDAN ÖNCE,
CAM ve TAKOZLAMA İŞLEMİ YAPILMALIDIR.

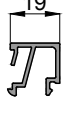
THE PANE MUST BE SHIMMED IN THE SASH SO THAT THE SASH OPERATES WITHOUT ADJUSTMENT OF THE HARDWARE.

CAM KALINLIĞI glass thickness	ÇITA glazing bead		CAM CONTASI glazing gasket	
	profil section	kod code	conta şekli section	kod code
18mm	P 2184 (37mm)			800 278 (10mm)
20mm				800 277 (8mm)
22mm				800 271 (6mm)
24mm	P 2183 (31mm)			800 278 (10mm)
26mm				800 277 (8mm)
28mm				800 271 (6mm)
30mm	P 2182 (25mm)			800 278 (10mm)
32mm				800 277 (8mm)
34mm				800 271 (6mm)
36mm	P 2181 (19mm)			800 278 (10mm)
38mm				800 277 (8mm)
40mm				800 271 (6mm)
42mm	P 2180 (13mm)			800 278 (10mm)
44mm				800 277 (8mm)
46mm				800 271 (6mm)



Yanda tablodaki veriler teoriktir.
Lütfen cam ve conta toleranslarını dikkate alınız.
selection tables promise a first planning.
Please keep the glass and gasket tolerances in mind.



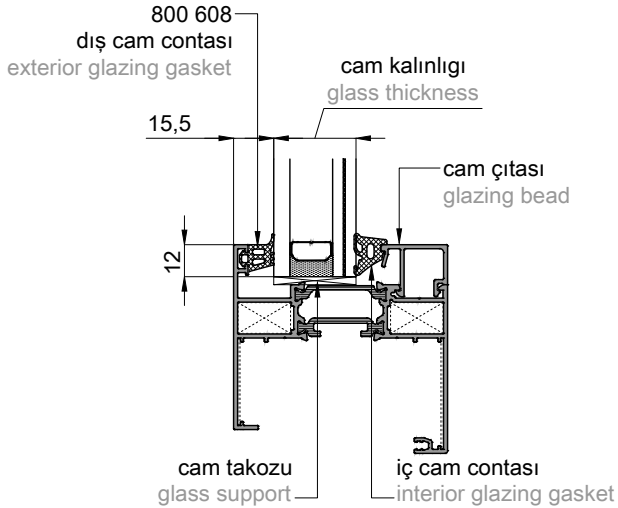







CAM KALINLIĞI glass thickness	ÇITA glazing bead		CAM CONTASI glazing gasket	
	profil section	kod code	conta şekli section	kod code
18mm	P 2184 (37mm)			800 278 (10mm)
20mm				800 277 (8mm)
22mm				800 271 (6mm)
24mm	P 2183 (31mm)			800 278 (10mm)
26mm				800 277 (8mm)
28mm				800 271 (6mm)
30mm	P 2182 (25mm)			800 278 (10mm)
32mm				800 277 (8mm)
34mm				800 271 (6mm)
36mm	P 2181 (19mm)			800 278 (10mm)
38mm				800 277 (8mm)
40mm				800 271 (6mm)
42mm	P 2180 (13mm)			800 278 (10mm)
44mm				800 277 (8mm)
46mm				800 271 (6mm)



Yanda tablodaki veriler teoriktir.
Lütfen cam ve conta toleranslarını dikkate alınız.
selection tables promise a first planning.
Please keep the glass and gasket tolerances in mind.

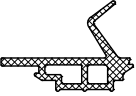





SMARTplus+
ÇEK-SÜR KAPI ve PENCERE SİSTEMİ
PULL&SLIDE DOOR and WINDOW SYSTEM

CONTALAR
GASKETS

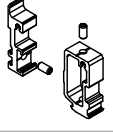
CONTA ŞEKLİ GASKET SECTION	CONTA KODU GASKET NO	MALZEME MATERIAL	CONTA TANIMI GASKET DESCRIPTION	PAKET PACKAGE
	800 271	EPDM	6mm İÇ CAM CONTASI interior glazing gasket	185mt/pk 0,081kg/mt
	800 277	EPDM	8mm İÇ CAM CONTASI 8mm interior glazing gasket	165mt/pk 0,092kg/mt
	800 278	EPDM	10mm İÇ CAM CONTASI 10mm interior glazing gasket	115mt/pk 0,130kg/mt
	800 608	EPDM	DIŞ CAM CONTASI exterior glazing gasket	144mt/pk 0,104kg/mt
	800 640	EPDM	KANAT BİNİ CONTASI overlap gasket for sash	167mt/pk 0,090kg/mt
	800 641	EPDM	KANAT BİNİ CONTASI overlap gasket for sash	357mt/pk 0,042kg/mt
	800 642	EPDM	KASA BİNİ CONTASI overlap gasket for frame	69mt/pk 0,216kg/mt
	800 643	EPDM	ÇİFT KANAT BİNİ CONTASI overlap gasket for double sash	230mt/pk 0,065kg/mt
	800 645	EPDM	BİTİŞ YALITIM CONTASI finishing insulation gasket	165mt/pk 0,091kg/mt
	800 234	EPDM	Ø4mm YUVARLAK CONTA Ø4 oring gasket	500mt/pk 0,017kg/mt

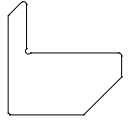
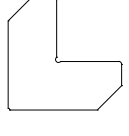
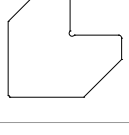
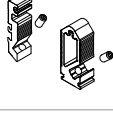
SMARTplus+
ÇEK-SÜR KAPI ve PENCERE SİSTEMİ
PULL&SLIDE DOOR and WINDOW SYSTEM

AKSESUARLAR
ACCESSORIES

AKSESUAR ŞEKLİ ACCESSORIES SHAPE	AKSESUAR ACCESS. NO	AKSESUAR TANIMI ACCESSORIES DESCRIPTION	MİKTAR QUANTITY
	700 686	KASA ve ORTA KAYIT BİRLEŞİM ANKRAJI T connection bracket for frame and mullion	50 adet/pieces
	700 451	SU TAHLİYE KAPAGI weep hole cap	50 adet/pieces
	701 185	0,8mm PASLANMAZ KÖŞE ONBAŞI 0,8mm stainless steel corner angle	100 adet/pieces
	701 186	0,8mm PASLANMAZ KÖŞE ONBAŞI 0,8mm stainless steel corner angle	100 adet/pieces
	701 187	0,8mm PASLANMAZ KÖŞE ONBAŞI 0,8mm stainless steel corner angle	100 adet/pieces
	701 188	KASA ve ORTA KAYIT BİRLEŞİM ANKRAJI T connection bracket for frame and mullion	50 adet/pieces
	701 189	KASA ve ORTA KAYIT BİRLEŞİM SÜNGERİ T connection foam for frame and mullion	50 adet/pieces
	701 190	KASA ve ORTA KAYIT BİRLEŞİM SÜNGERİ T connection foam for frame and mullion	50 adet/pieces
	701 191	KASA ve ORTA KAYIT BİRLEŞİM SÜNGERİ T connection foam for frame and mullion	50 adet/pieces
	701 192	ALT BİTİŞ MONTAJ KLİPSİ injection clip for finishing angle	100 adet/pieces

AKSESUAR ŐEKLİ ACCESSORIES SHAPE	AKSESUAR ACCESS. NO	AKSESUAR TANIMI ACCESSORIES DESCRIPTION	MİKTAR QUANTITY
∅	701 193	PASLANMAZ ÇELİK RAY Stainless Steel Rail	30mt 3mt X 10pieces

SMARTplus+
ÇEK-SÜR KAPI ve PENCERE SİSTEMİ
PULL&SLIDE DOOR and WINDOW SYSTEM

PLASTİK PROFİLLER
PVC PROFILES

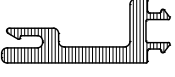
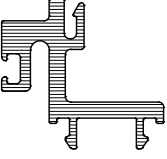
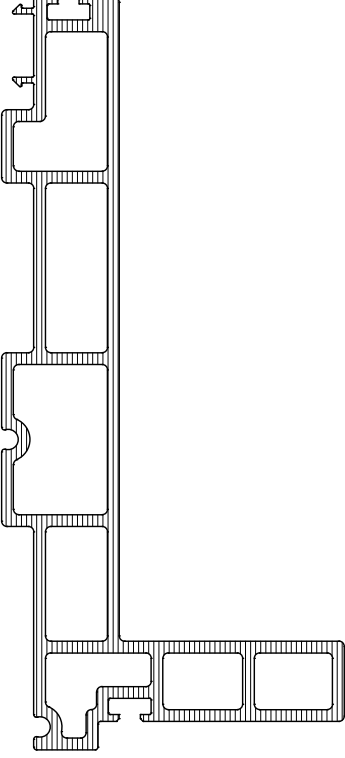
PROFİL ŞEKLİ PROFILE SECTION	PROFİL KODU PROFILE NO	MALZEME MATERIAL	PROFİL TANIMI PROFILE DESCRIPTION	PAKET PACKAGE
	600 495	polyamide	KENET İÇİN PVC PROFİL thermal insulation profile for interlock	6mt 25ad/pk 0,180kg/mt
	600 496	polyamide	KASA İÇİN PVC PROFİL thermal insulation profile for frame	6mt 25ad/pk 0,295kg/mt
	600 498	PVC	SÜRME DOGRAMA KÖRKASA İZOLATÖR PROFİLİ sliding window system subframe insulation profile	6mt 25ad/pk 1,625kg/mt

SMARTplus+
ÇEK-SÜR KAPI ve PENCERE SİSTEMİ
PULL&SLIDE DOOR and WINDOW SYSTEM

TAM ÖLÇEKLİ PROFİLLER
FULL SCALE PROFILES

P 2193

Kasa Profili / Frame Profile
1,770kg/mt

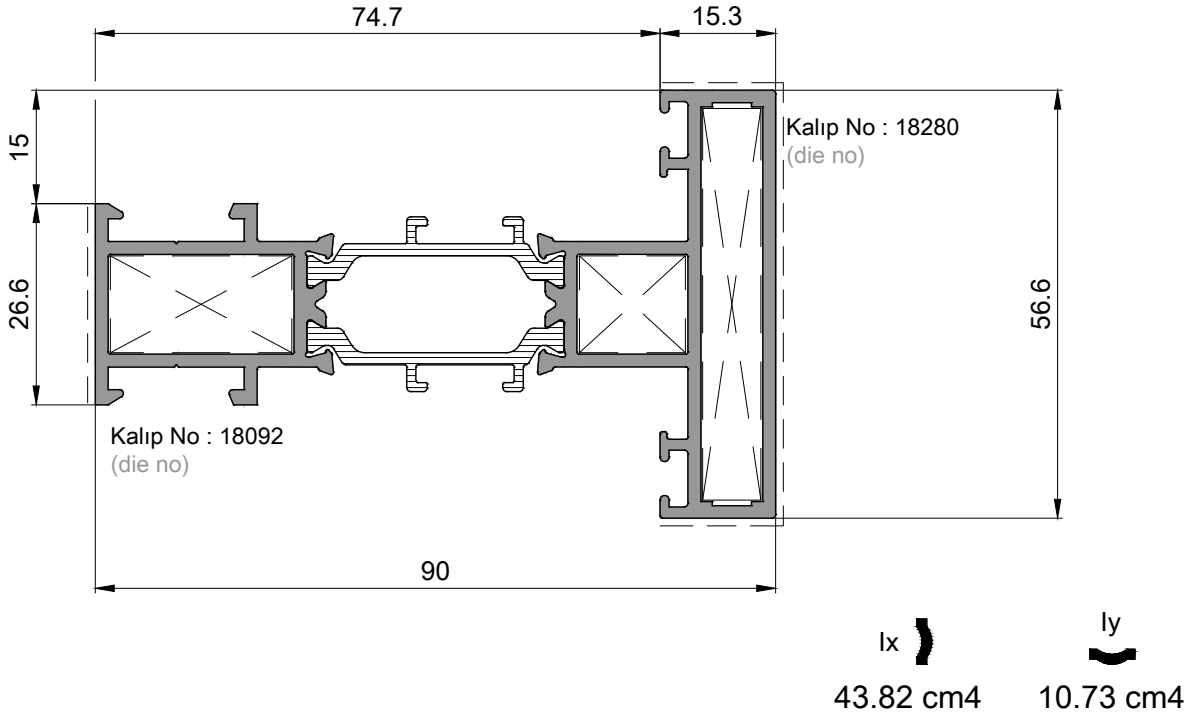

P 2405

Orta Kayıt Profili / Mullion Profile
1,425kg/mt

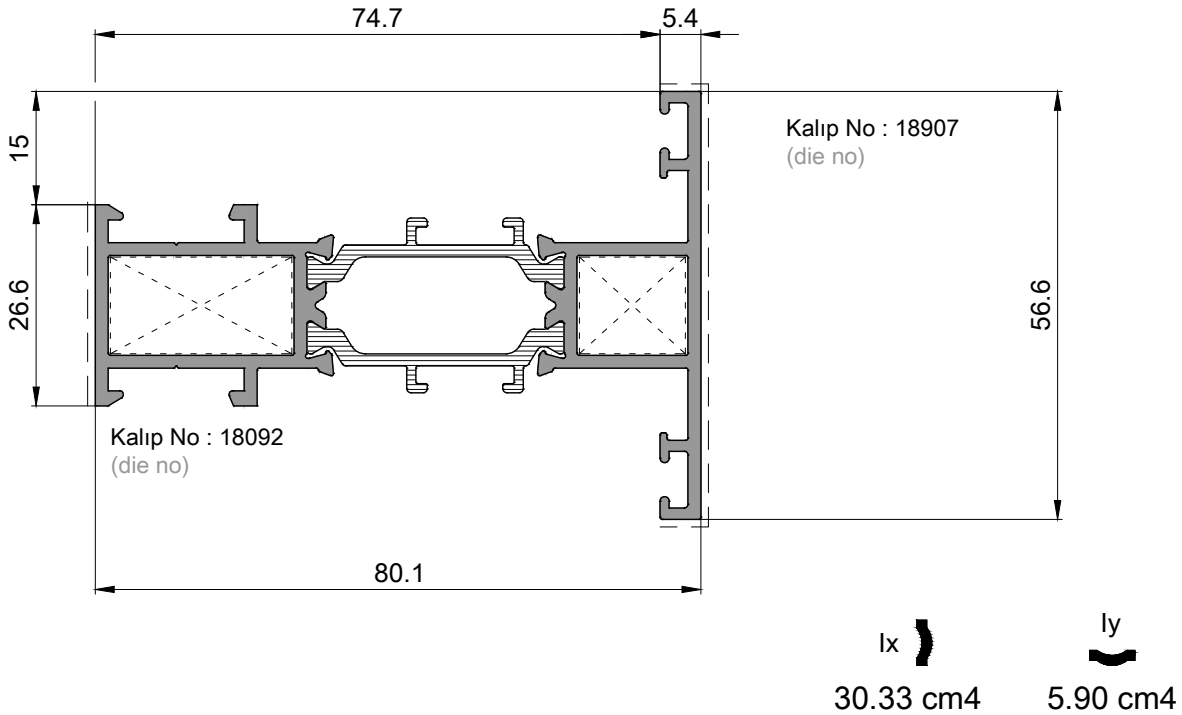

P 2407
Orta Kayıt Profili / Mullion Profile
2,405kg/mt

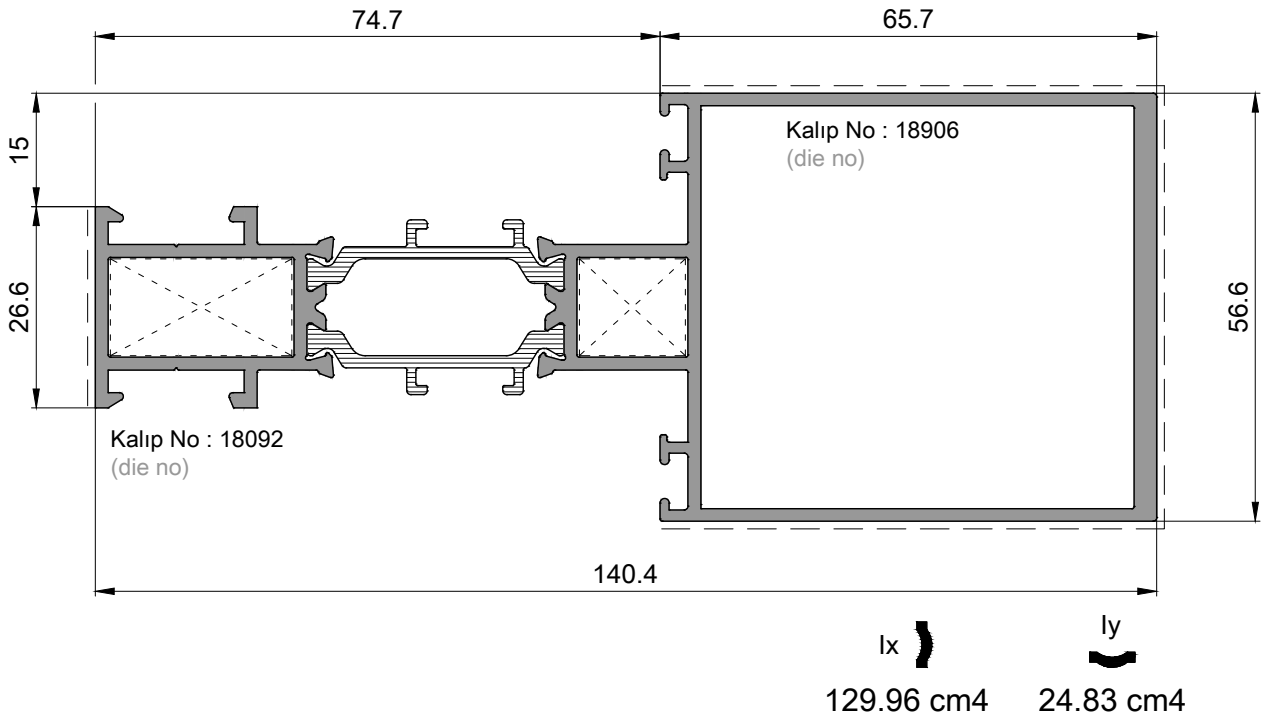

P 2475
Kasa Profili / Frame Profile
2,470kg/mt

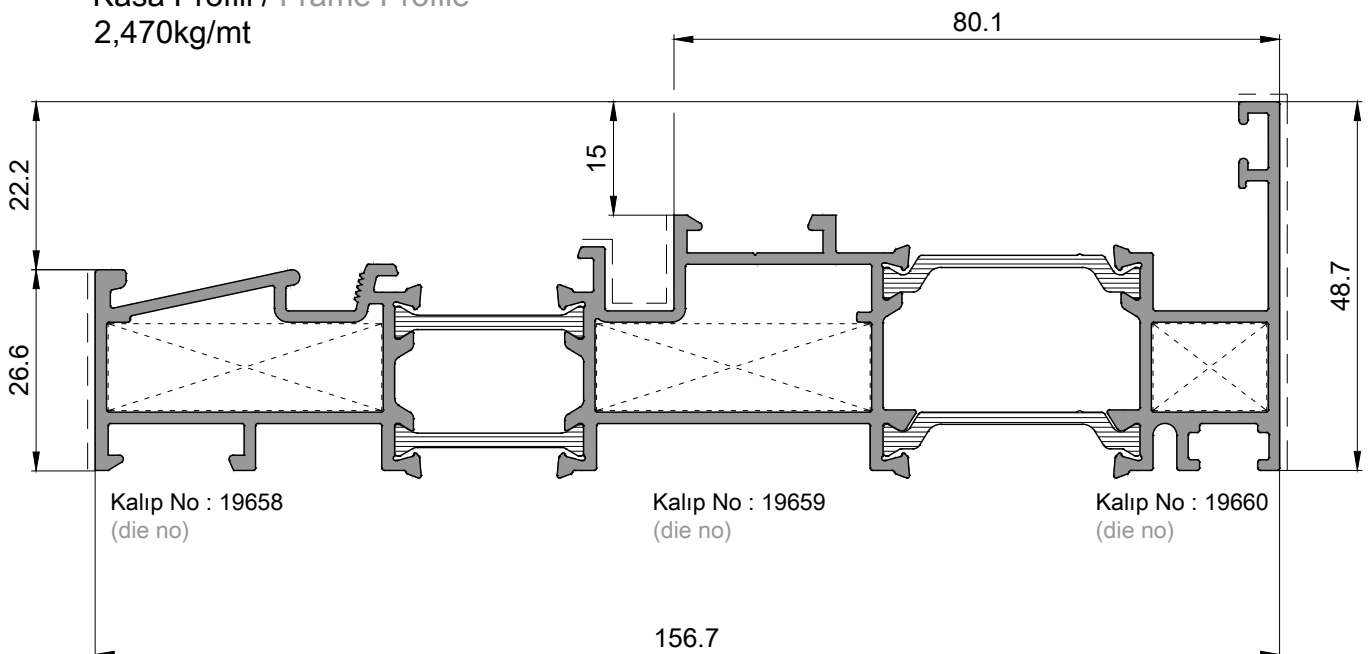

P 2476
Kanat Profili / Sash Profile
1,620kg/mt

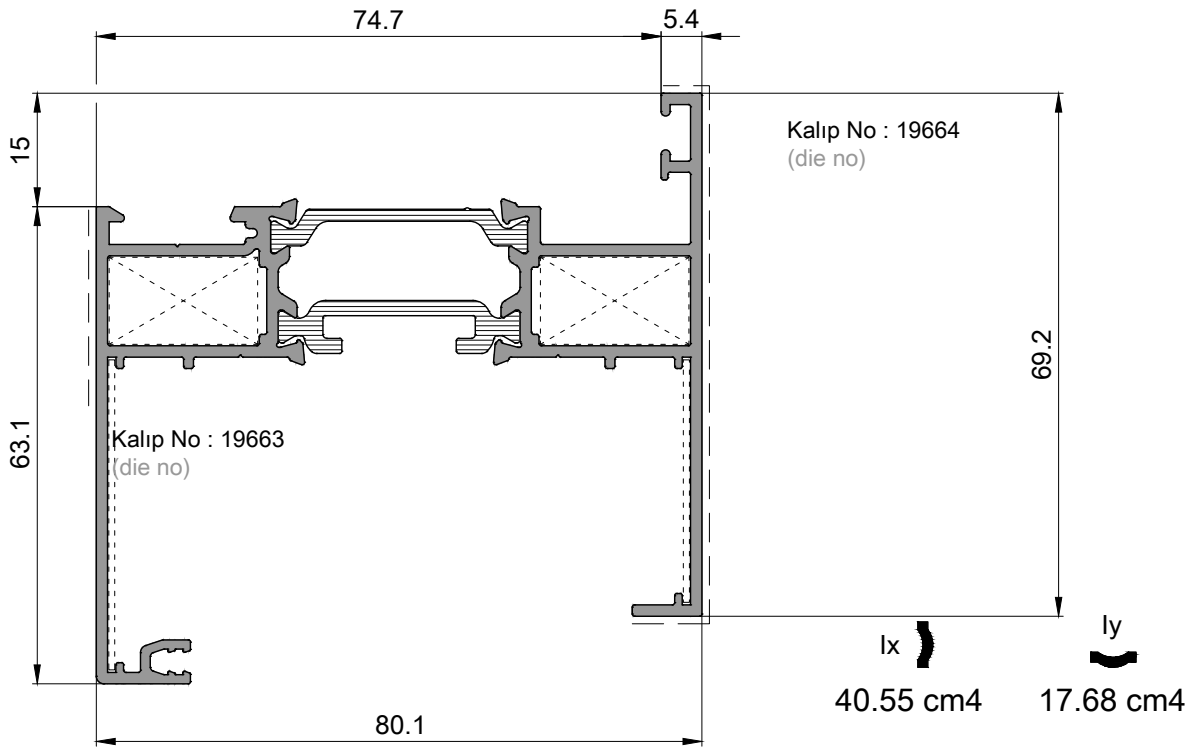

P 2477
Kanat Profili / Sash Profile
1,365kg/mt

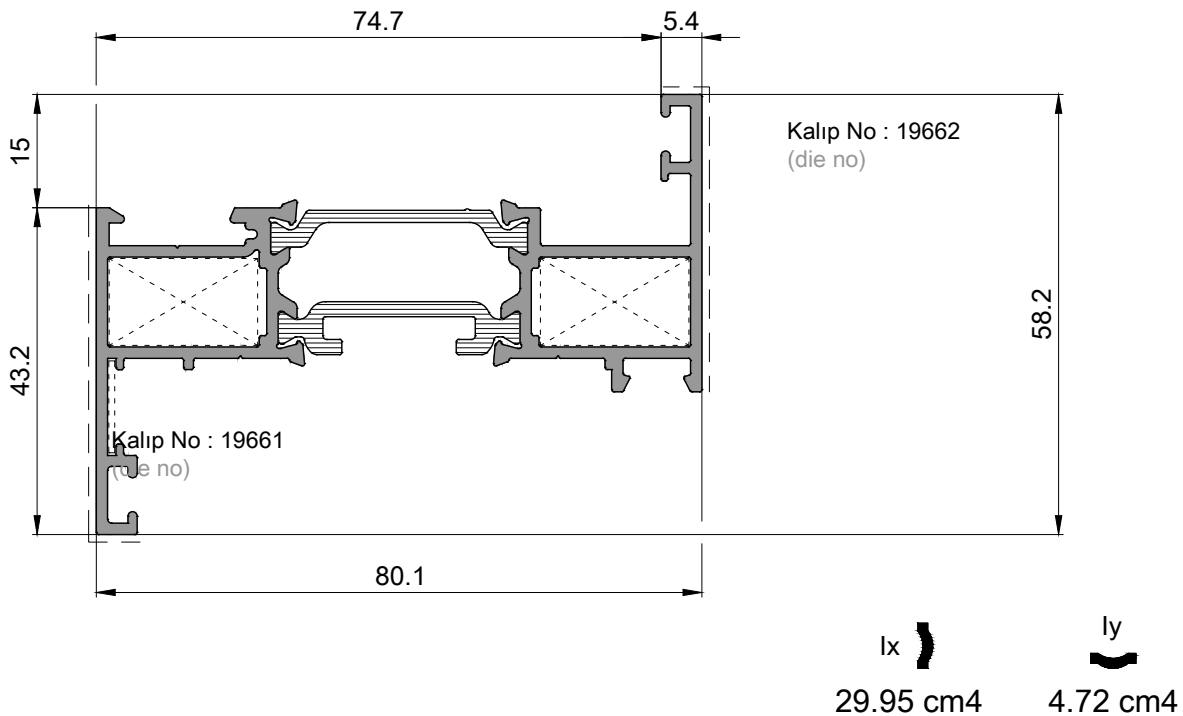

P 2478

Orta Kayıt Profili / Mullion Profile
1,415kg/mt

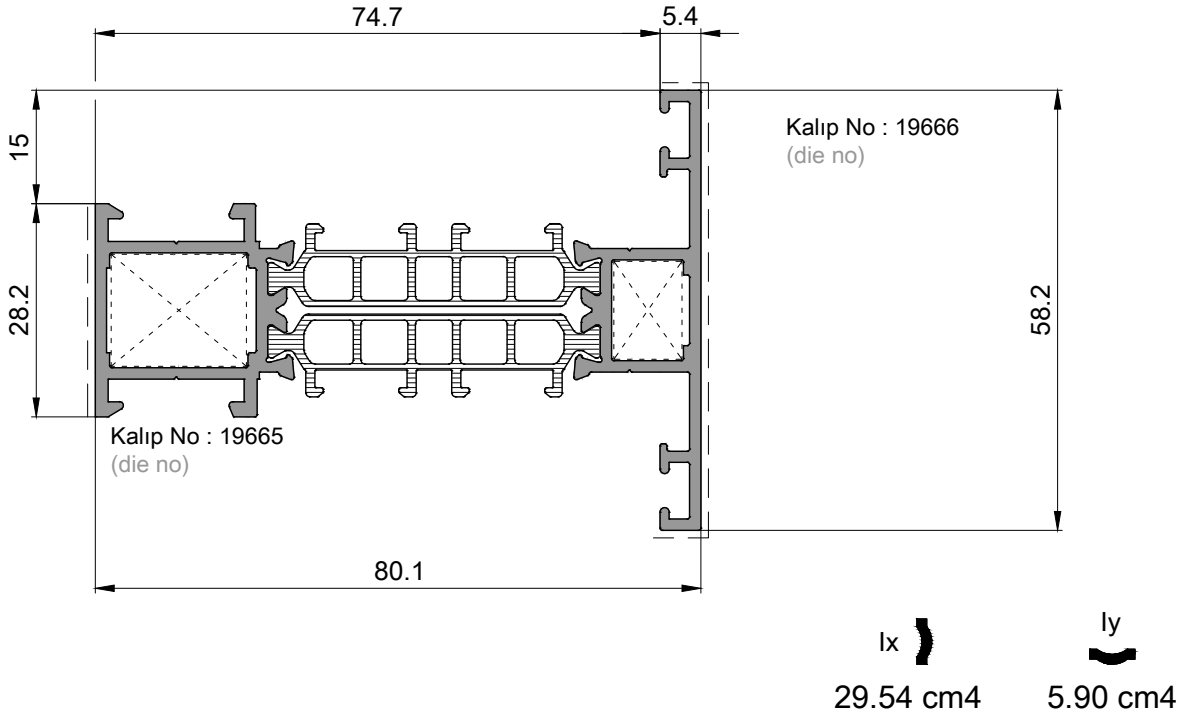

P 2479

Orta Kayıt Profili / Mullion Profile
2,200kg/mt

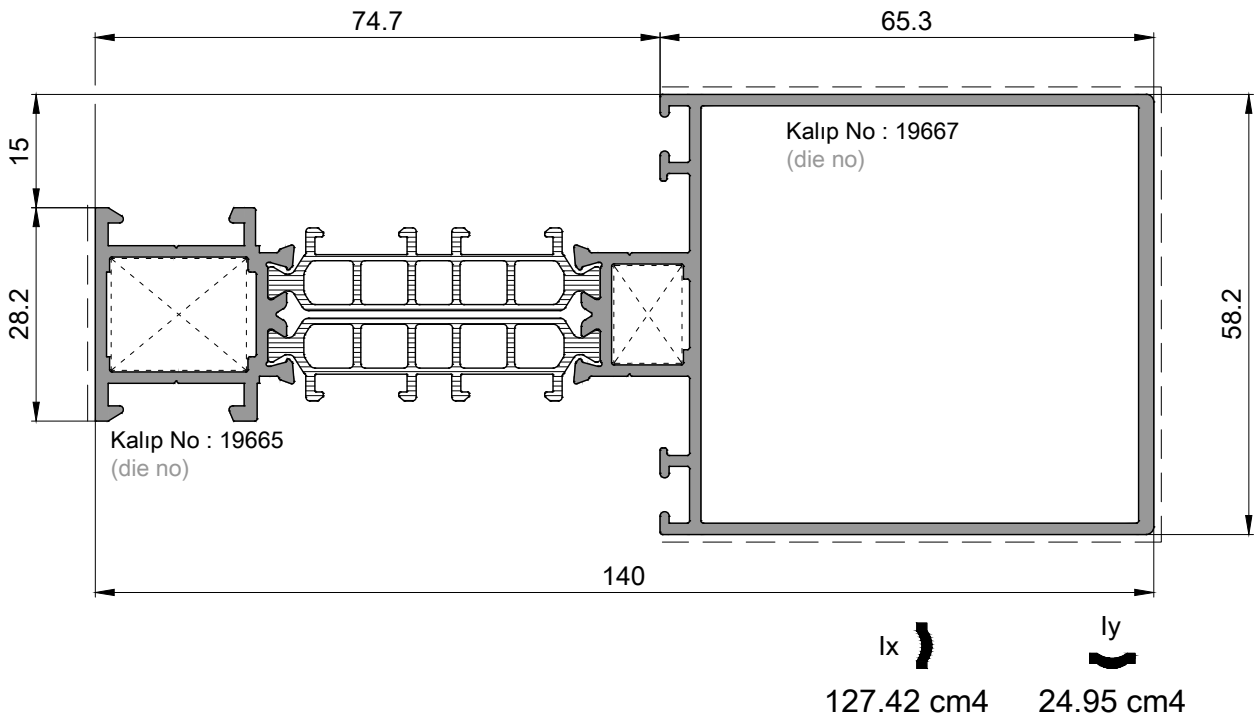

P 2480
Adaptör Profili / Adepter Profile
1,510kg/mt

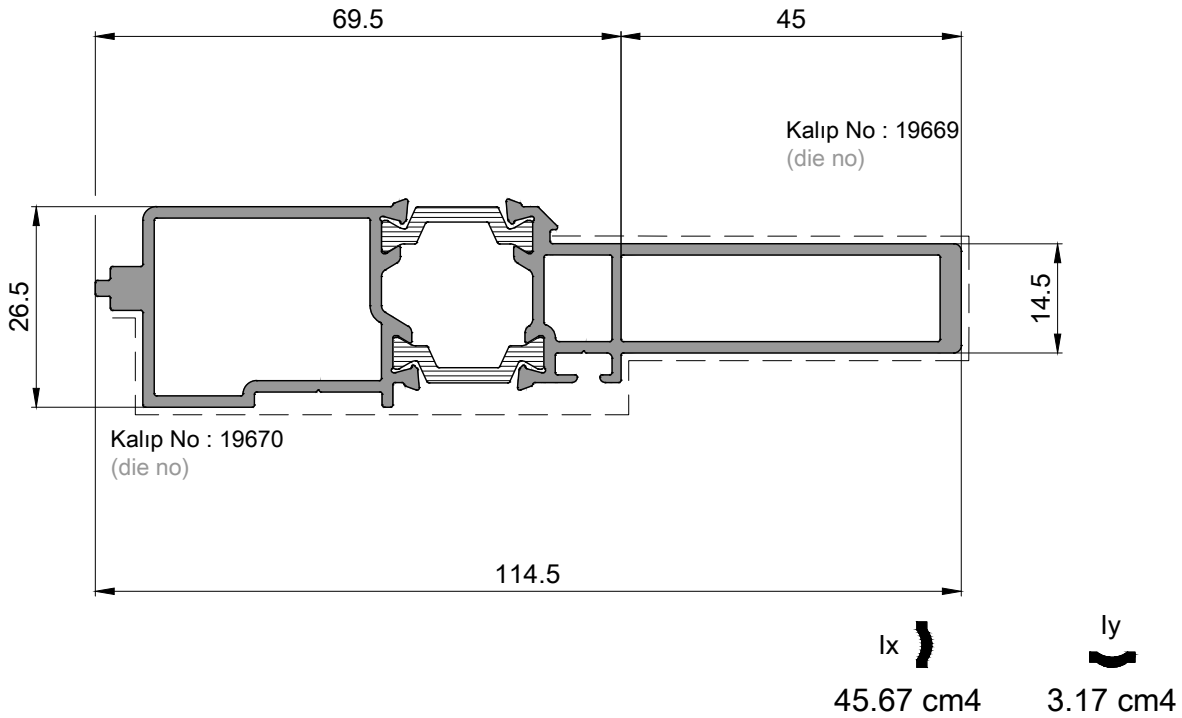

P 2481
Adaptör Profili / Adepter Profile
0,880kg/mt

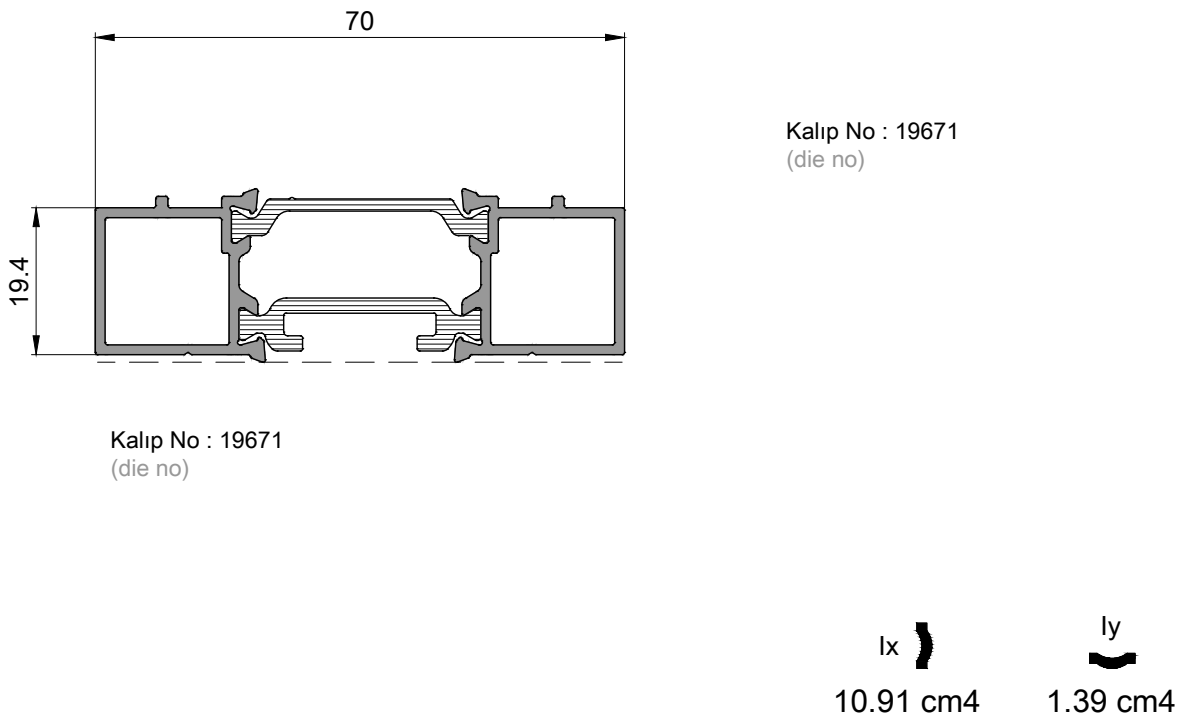

P 2482

Kapak Profili / Closing Profile
0,420kg/mt

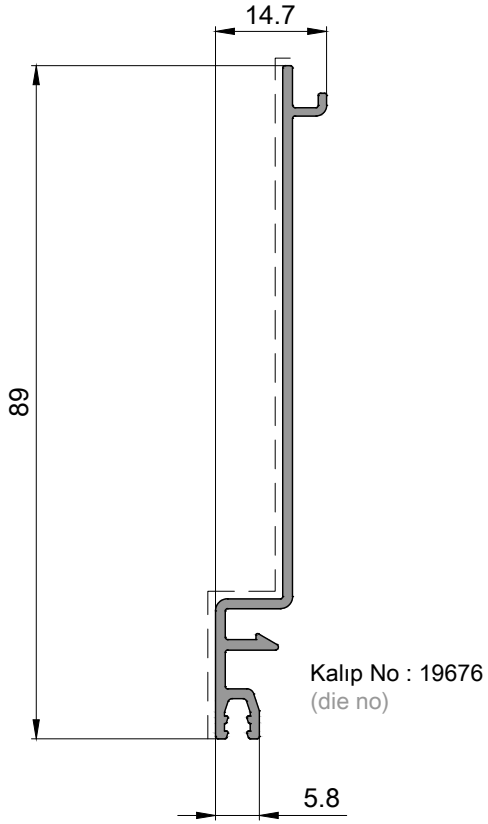

P 2483

Kapak Profili / Closing Profile
0,460kg/mt

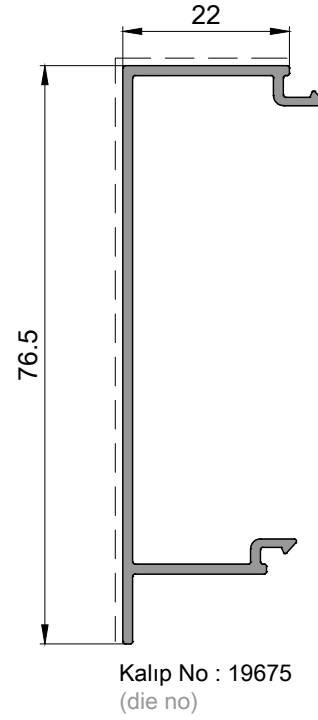

P 1163

Köşe Takoz Profili / corner joint profile
3,750kg/mt

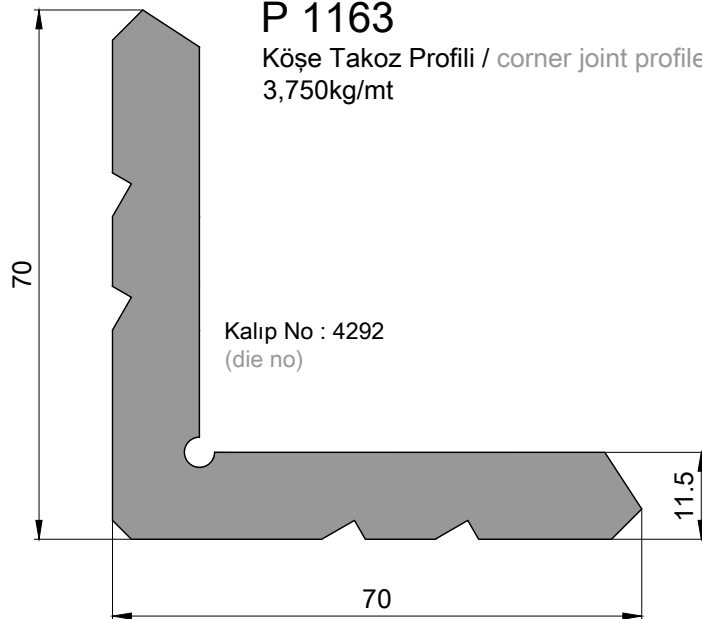

P 2180

Çita Profili / glazing bead profile
0,240kg/mt

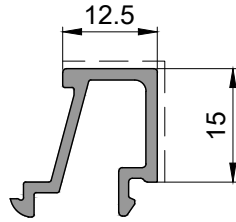

P 2181

Çita Profili / glazing bead profile
0,285kg/mt

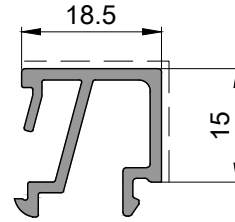

Kalıp / die no : 18279

P 2182

Çita Profili / glazing bead profile
0,295kg/mt

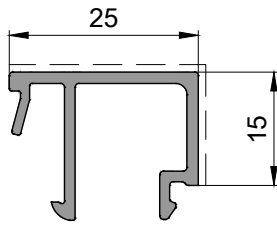

Kalıp / die no : 18096

P 2183

Çita Profili / glazing bead profile
0,320kg/mt

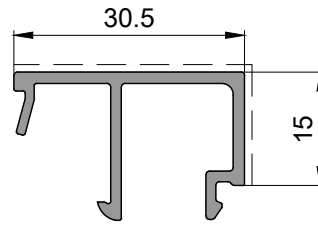

P 2184

Çita Profili / glazing bead profile
0,340kg/mt

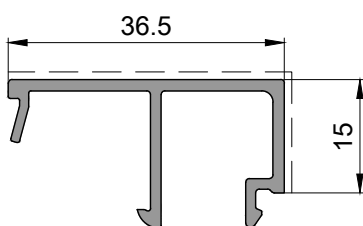

P 1020

Tij Profili / rodprofile
0,105kg/mt

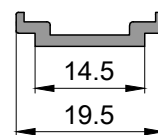

Kalıp : 12769
(die no)

eloxal - anodising

P 2484

Alt Ray Profili / bottom rail profile
0,690kg/mt

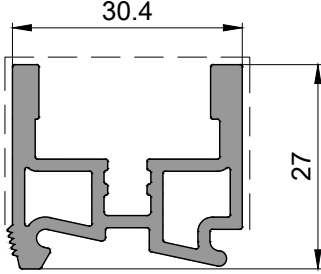

Kalip No : 19672
(die no)

P 2485

Üst Ray Profili / top rail profile
0,765kg/mt

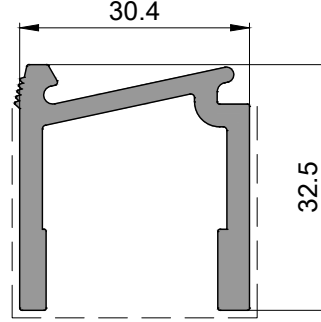

Kalip No : 19673
(die no)

P 2486

Yan Ray Profili / side rail profile
0,485kg/mt

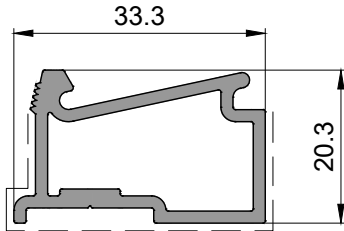

Kalip No : 19674
(die no)

P 2487

Bitiş Profili / Finishing profile
0,120kg/mt

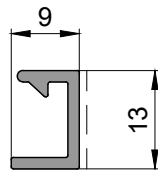

Kalip No : 19677
(die no)

P 2488

Ray Profili / Rail Profile
0,170kg/mt

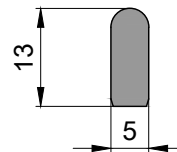

Kalip No : 19678
(die no)

SMARTplus+
ÇEK-SÜR KAPI ve PENCERE SİSTEMİ
PULL&SLIDE DOOR and WINDOW SYSTEM

PRENSİP SİSTEM DETAYLARI
PRINCIPAL SECTIONS

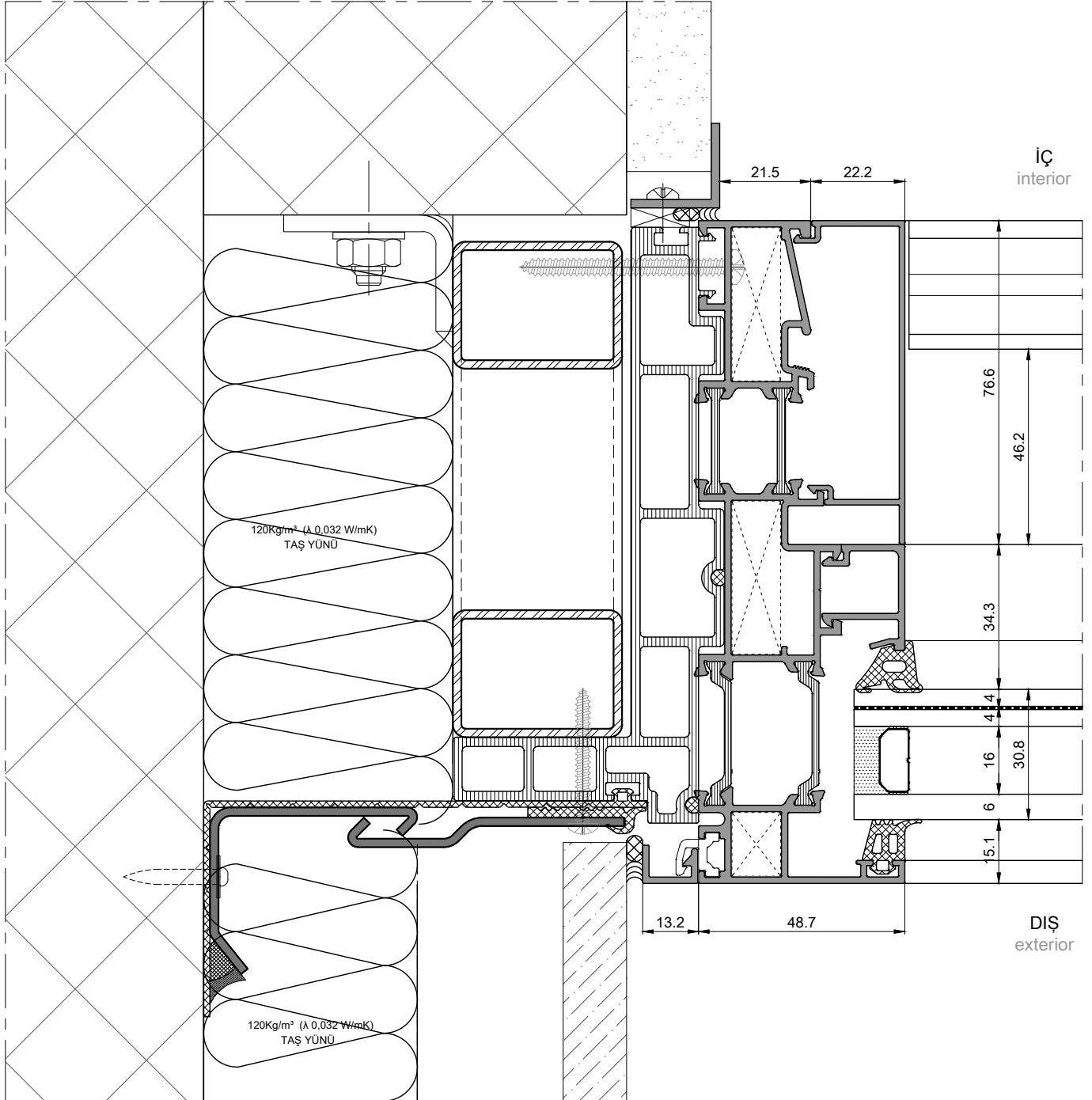
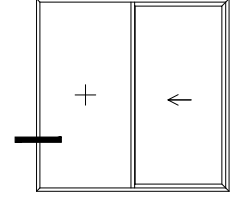

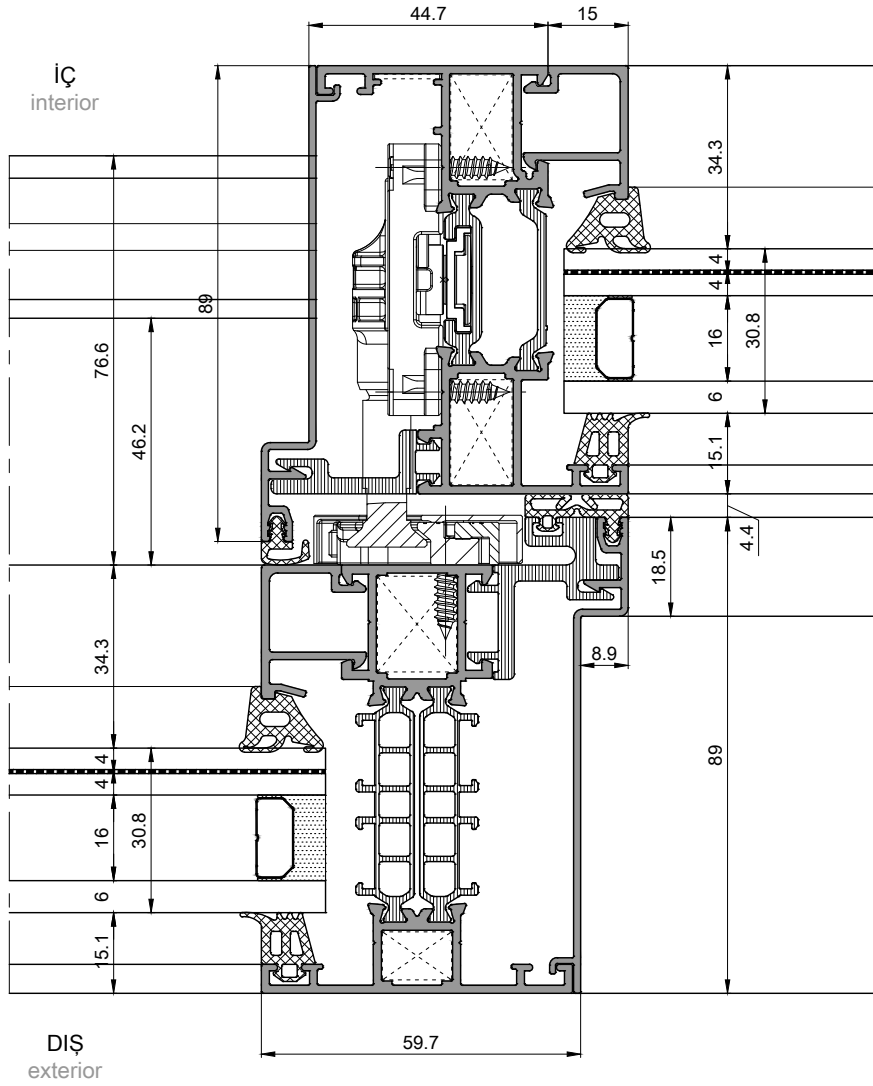
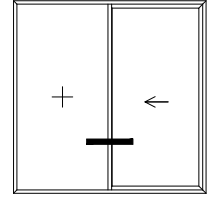

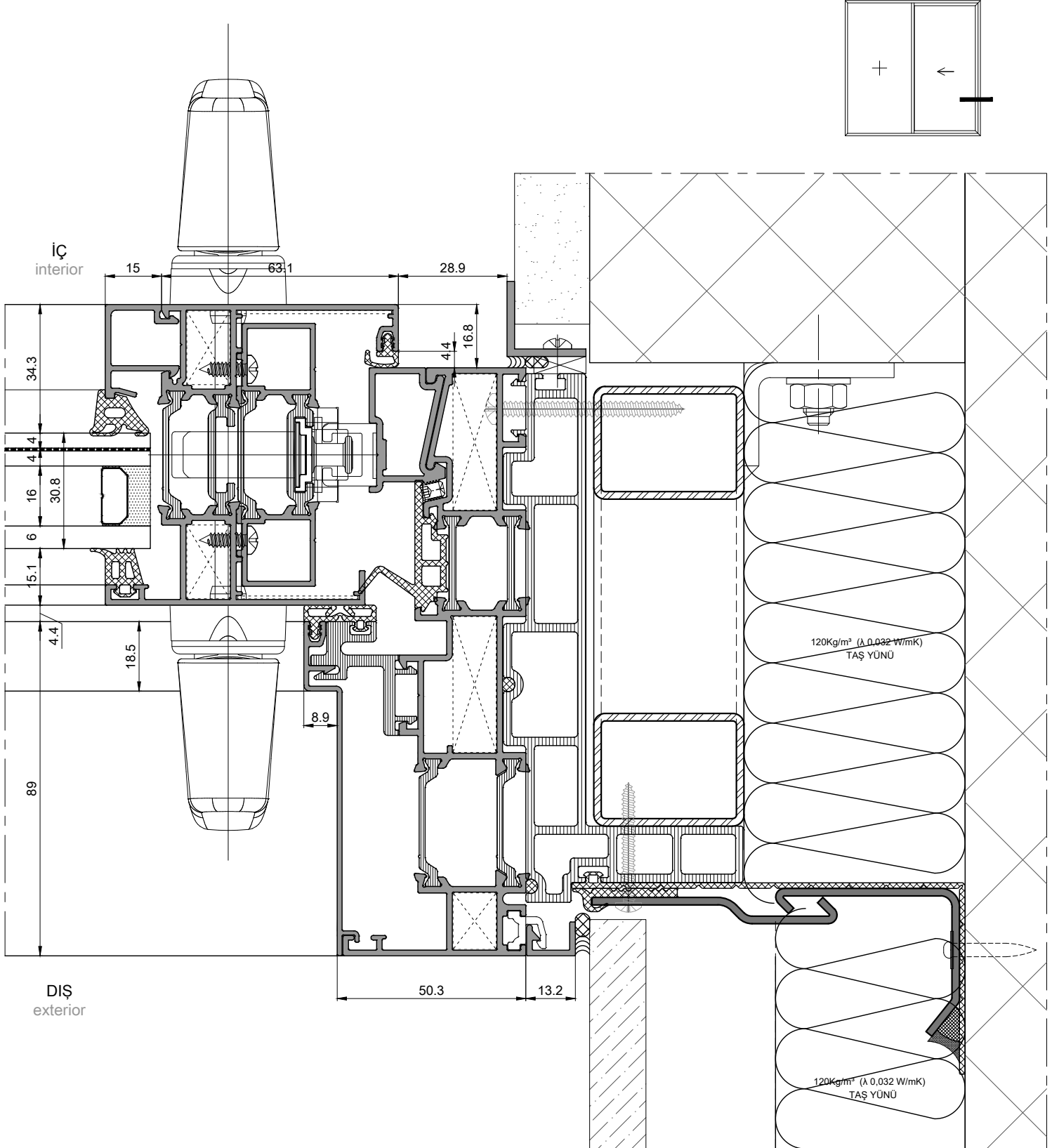

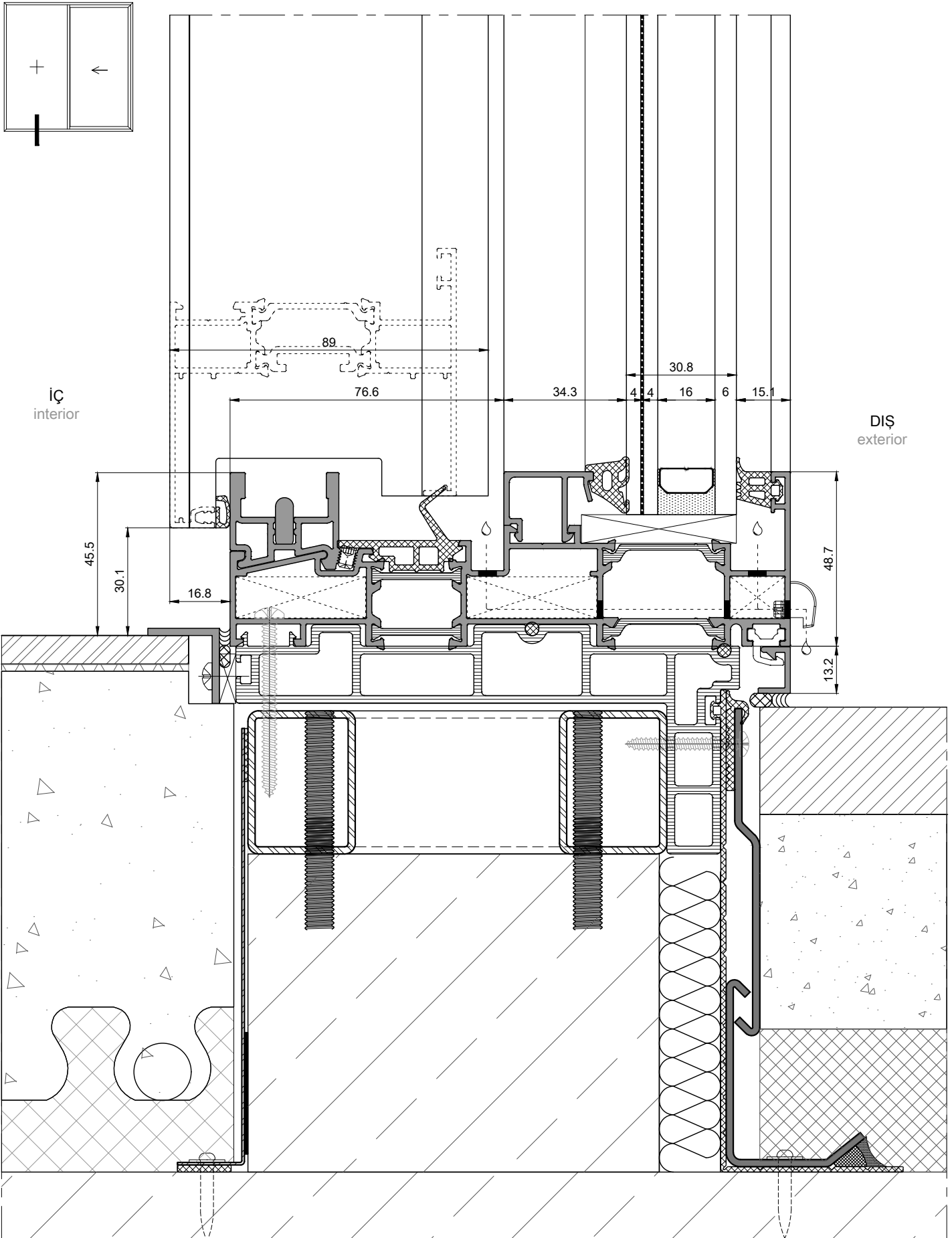

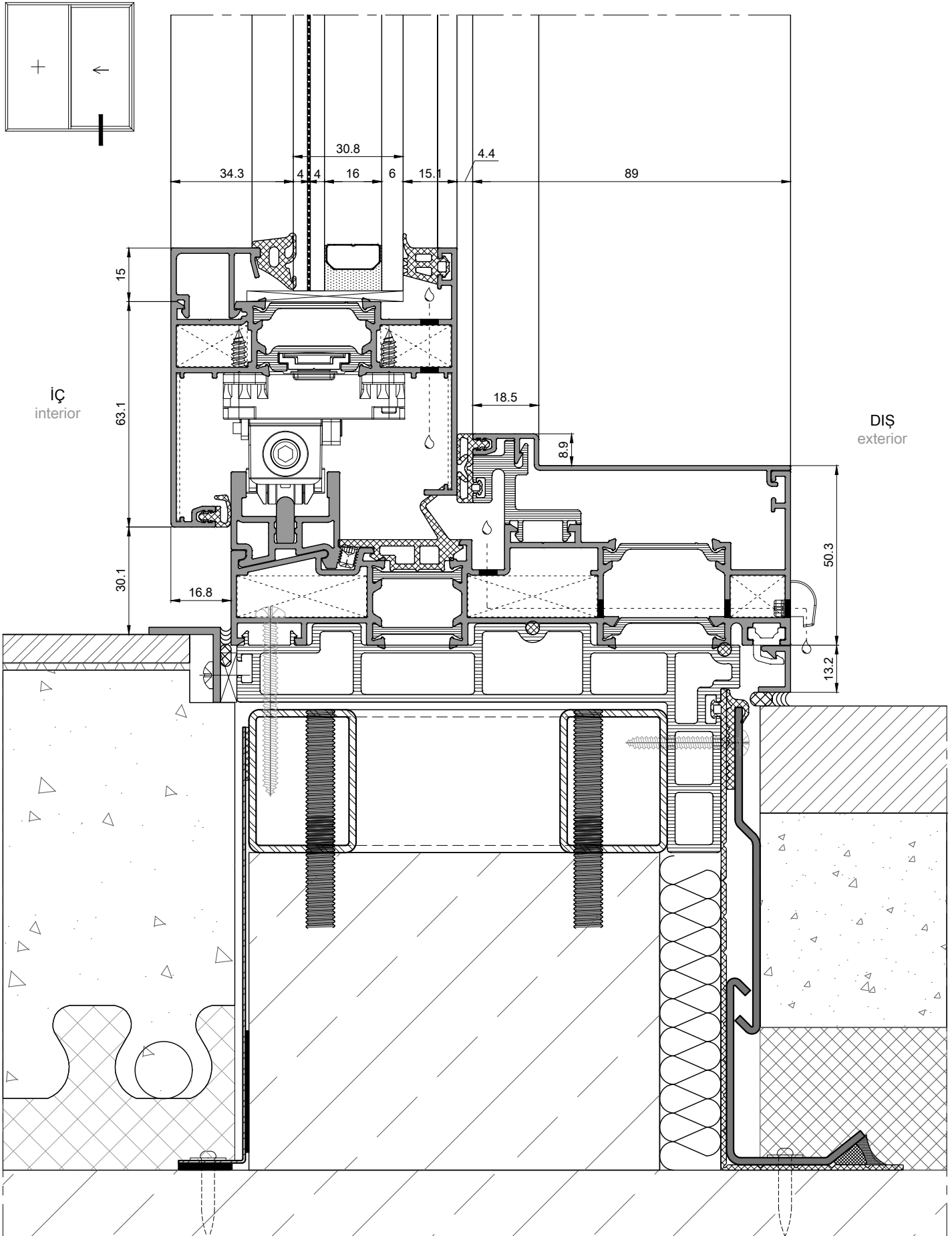

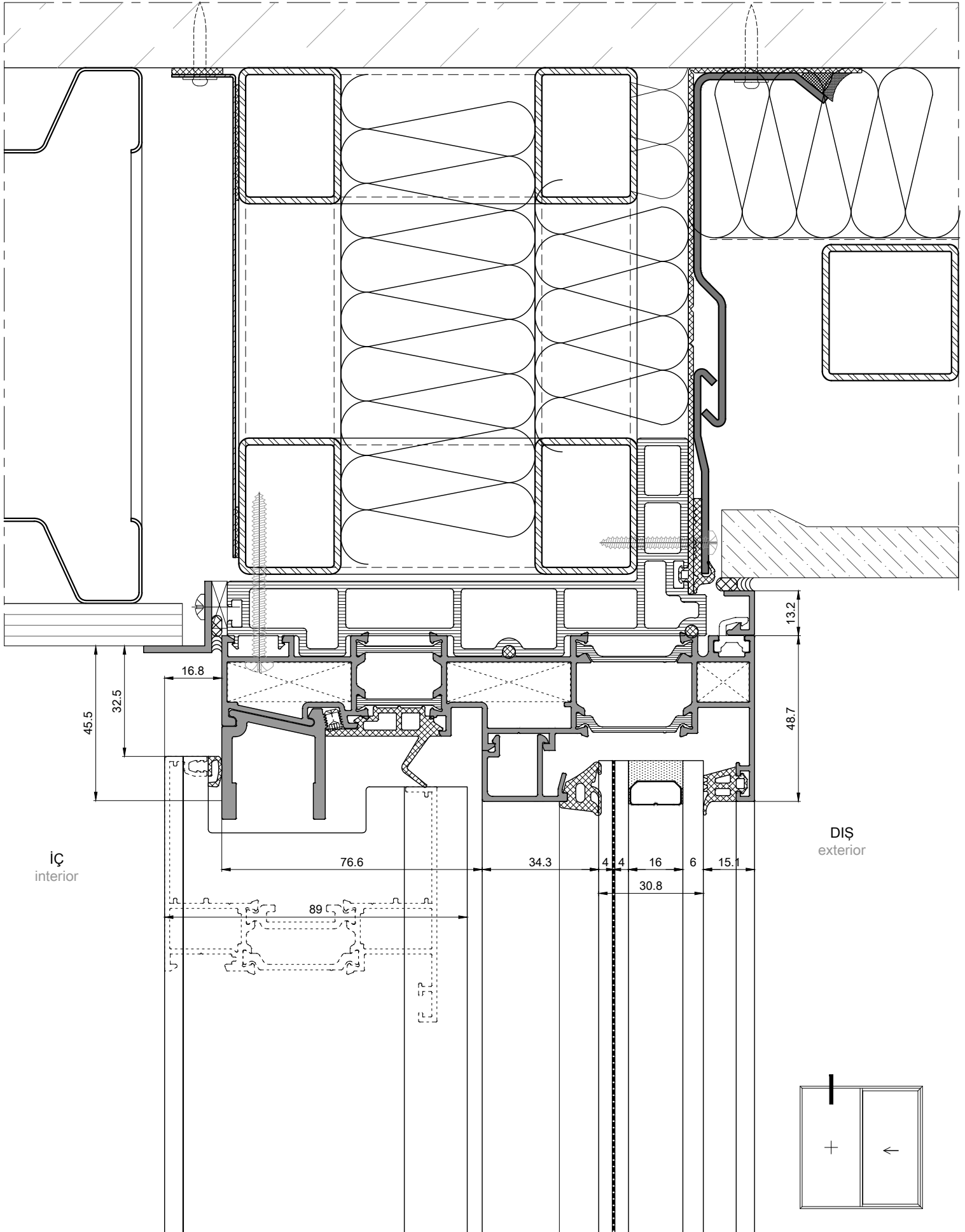

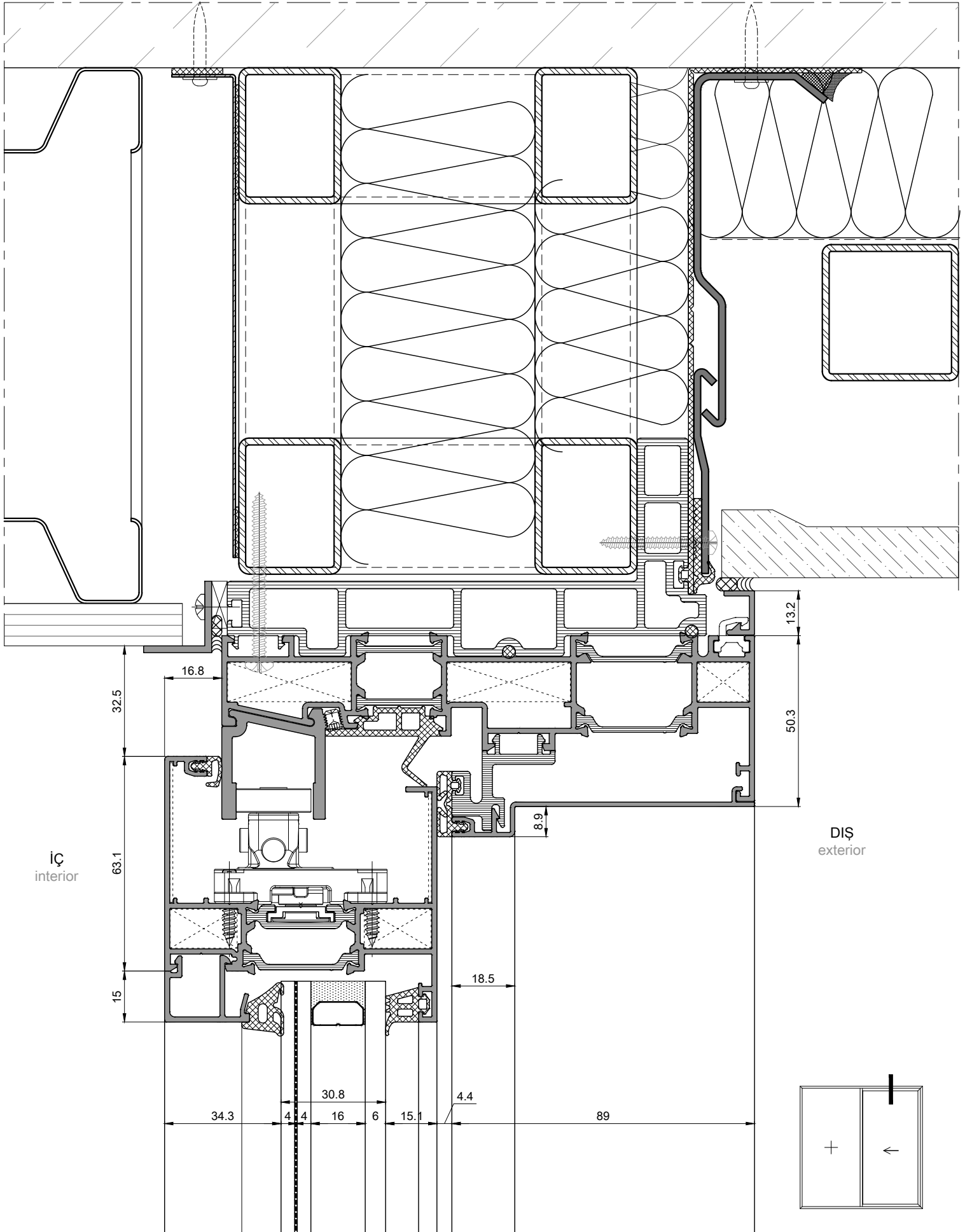

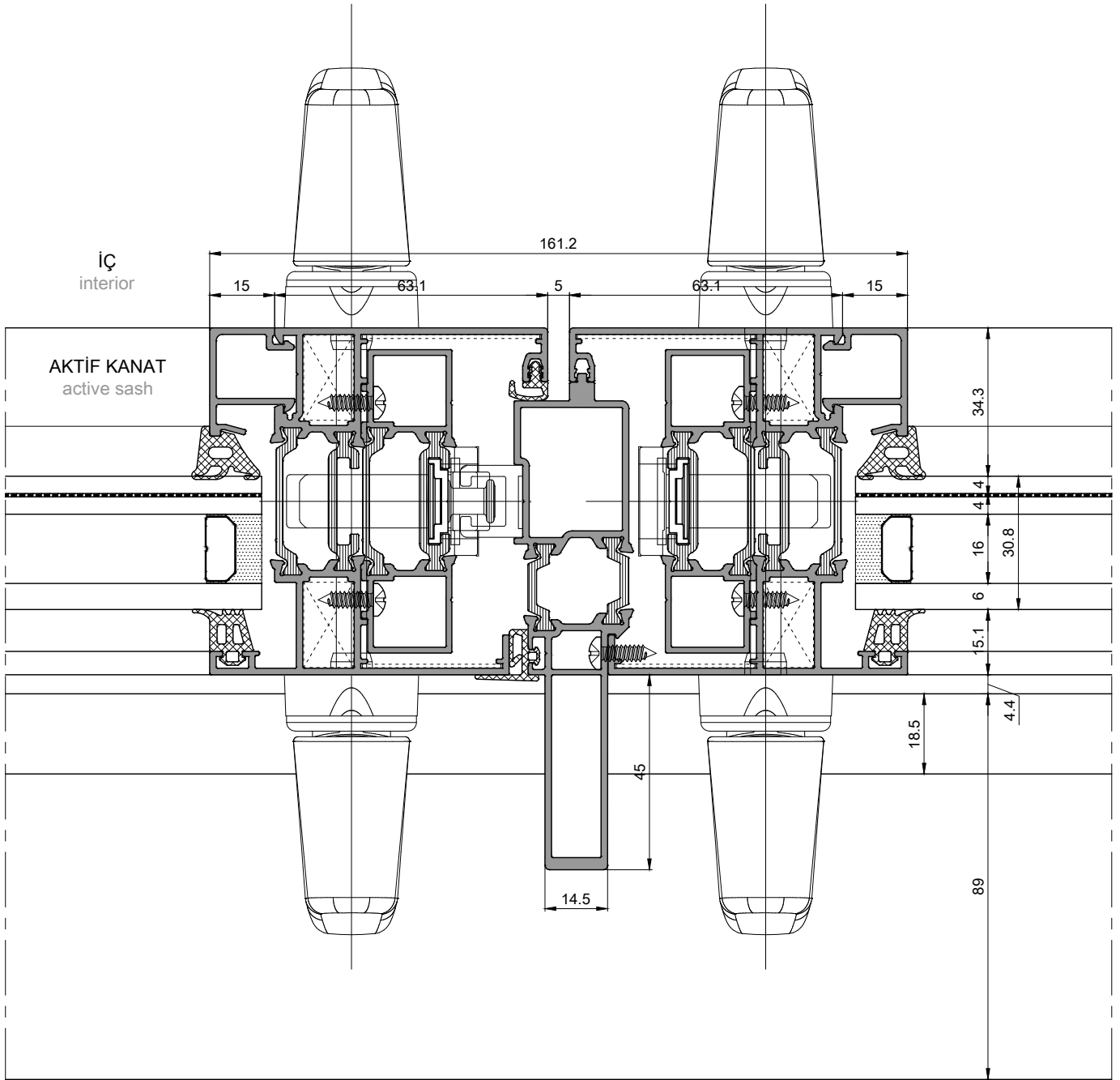

AKTİF KANAT
active sash

